

BIOTRAK® REAL-TIME VIABLE PARTICLE COUNTER

CONTINUOUS ENVIRONMENTAL MONITORING IN FILL-FINISH: RETURN ON INVESTMENT

The BioTrak® Real-Time Viable Particle Counter is a full featured instrument that integrates an ISO-compliant particle counter with state-of-the-art viability determination. It also incorporates a particle collection filter so the optically analyzed particles are available for subsequent culture to confirm and identify microorganisms. With this, the BioTrak Real-Time Viable Particle Counter provides continuous monitoring indefinitely while its collection filter maintains viability for up to nine hours.

This document provides guidance for writing a compelling return on investment (ROI) document. Although value can be realized through a number of applications, this document focuses on the ROI for continuous, in-process environmental monitoring in Grade A spaces. It highlights clearly identified cost savings and the process efficiencies that the BioTrak Real-Time Viable Particle Counter brings to aseptic manufacturing facilities.



CONTINUOUS, IN-PROCESS ENVIRONMENTAL MONITORING IN GRADE A FILL-FINISH SPACES

Application

The BioTrak Real-Time Viable Particle Counter provides continuous, ISO-compliant total particulate concentrations, continuous viable particulate concentrations, and captures microbial samples for subsequent culture. Typically, the BioTrak Real-Time Viable Particle Counter will be integrated into a facility monitoring system for this application (e.g. TSI's FMS 5 Software) whereby operation, data collection, analysis, alert/alarm functions and batch reporting are fully automated. The full benefits of the BioTrak Real-Time Viable Particle Counter are realized after removal of traditional methods and modification of SOPs to eliminate process interruptions for sampling plates which are no longer required when using the BioTrak Real-Time Viable Particle Counter.

Business Benefits

Implementation of the BioTrak Real-Time Viable Particle Counter in fill-finish spaces eliminates the need for process interruptions for environmental microbial monitoring. In many cases, payback time can be less than one year even when considering maximal costs of implementation. Every aseptic fill-finish operation must perform in-process microbial monitoring to comply with Good Manufacturing Practices (GMP). These activities introduce significant risk and negatively impacts throughput. The cost savings achieved using the BioTrak Real-Time Viable Particle Counter for interruption-free, continuous in-process monitoring can be significant. The magnitude of these costs savings depends on several factors including: cost of goods manufactured, frequency and duration of microbial monitoring interventions, risk mitigation procedures, effects of stoppages on exposed or stagnant drug product and the capacity of the line.



UNDERSTANDING, ACCELERATED

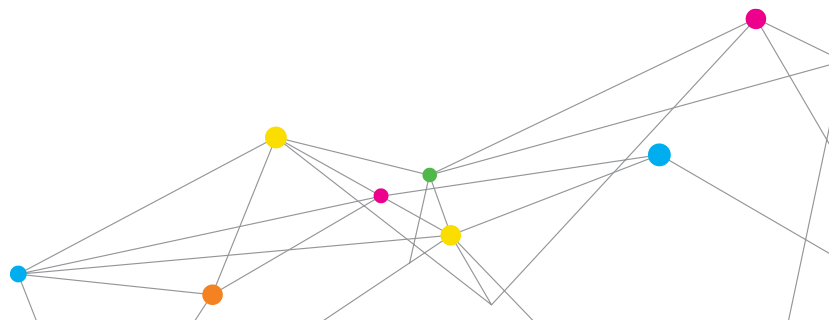

IMPLEMENTATION COSTS

Overview

The cost of switching from traditional methods to the BioTrak Real-Time Viable Particle Counter for in-process microbial monitoring are disproportionately incurred during the initial validation period. Once an organization has validated the instrument implantation on individual production lines, it is a less time-consuming endeavor.

Proof-of-Concept Validation

The cost associated with validating the BioTrak Real-Time Viable Particle Counter is estimated at \$110,000. This figure includes costs in relation to equipment and materials, vendor documentation, FTE time, on-site vendor training and qualification services.

Installation and Commissioning

System design, installation and qualification can vary depending on factors such as the number of desired sampling points and the scope of the design/installation (other software and/or environmental monitoring products involved). For a fill-finish line with five microbial sampling points, the cost of the system, fully installed and qualified, is \$390,000.

Method Suitability

Once the system is installed, FTE to collect, analyze and report the validation data required for regulatory acceptance is estimated at \$10,000.

Continuing Costs

Calibration and maintenance of a BioTrak Real-Time Viable Particle Counter is estimated at \$50,000/year.

Total Cost

With consideration for proof-of-concept validation and one year continuing costs, total cost for a five sample-point fill-finish line is estimated at \$560,000. Leveraging already completed proof-of-concept validation, an organization may implement additional lines (five samples each) with an estimated cost of \$450,000/line.



BUSINESS BENEFITS AND VALUE ACHIEVED

Overview

The actual cost savings achieved with integration of the BioTrak Real-Time Viable Particle Counter is highly dependent on the products and processes involved. Herein outlined are several potential cost saving mechanisms based on the elimination of interventions during production. The savings associated with each mechanism is dependent upon all the factors highlighted in the Continuous, In-process Environmental Monitoring in Grade A Fill-Finish Spaces: Business Benefits section of this document.

Maximizing Throughput

Reduce wasted drug product: During an intervention period, filled drug containers on the line undergo negative exposure, causing them to be rejected as waste. This practice mitigates risk but sacrifices throughput. The cost savings incurred by avoiding wasted drug product and container is dependent upon all factors highlighted in the Continuous, In-process Environmental Monitoring in Grade A Fill-Finish Spaces: Business Benefits section of this document.

Eliminate nozzle clogging: Many of today's biologic drug products are formulated at very high concentrations and present a challenge for automated fluid handling. One well known effect of stagnant drug product is dehydration and solidification at the exposed filling nozzle tip. This process is greatly exacerbated during periods of stoppage and can require flushing procedures that can waste relatively large volumes of drug product.

Increase capacity: Production interruptions can add days, even weeks, over the course of a year. Utilizing the BioTrak Real-Time Viable Particle Counter, much of this valuable production time is recovered, shortening batch processing times and freeing capacity for additional batches.

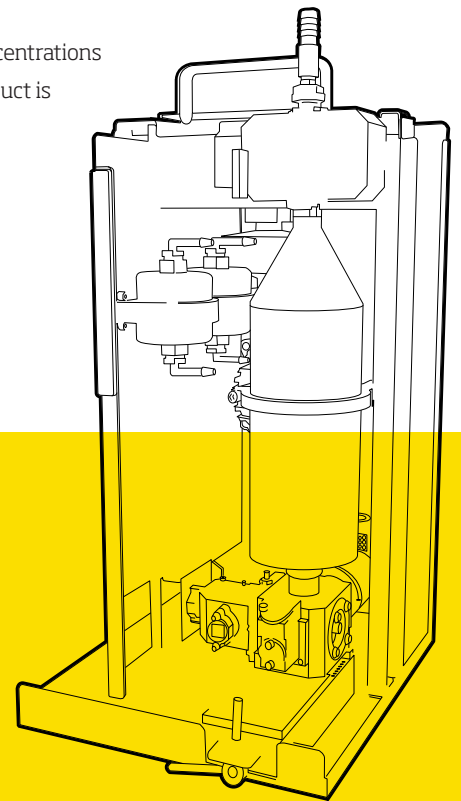

Reduce Cost of Goods Manufactured (COGM)

Reduce downtime: When lyophilizer capacity is sufficient, fill lines can become the bottleneck. The BioTrak Real-Time Viable Particle Counter can improve cycle times by eliminating downtime to perform microbial monitoring. Depending on the frequency and duration of the required microbial interventions, a given fill-finish line can experience a 10-20% reduction in uptime. With facility and personnel time as the highest typical cost for aseptic manufacturing, the BioTrak Real-Time Viable Particle Counter is able to eliminate downtime and associated costs.

Reduce microbiology costs: The actual cost of a single microbial experiment (i.e. one agar plate result) is estimated to be between \$60 and \$100, as reported direct by one large pharmaceutical firm. The associated costs include materials, equipment, validation, growth-promotion and facility costs as well as personnel costs. With the BioTrak Real-Time Viable Particle Counter, there is no need to process hundreds (or even thousands) of plates annually to perform in-process microbial monitoring—culture samples are needed only when they are detected. In Grade A spaces, this is a rare event.

Cost of quality: Avoid sub-lotting or additional sterility testing: Following production stoppages, sub-lotting product and performing additional quality testing to mitigate the risk associated with interruptions in the continuous flow of product through the manufacturing line is common. This approach is contrary to quality by design principles—adding to the cost of production and extending post-production hold times.

ROI EXAMPLES

To demonstrate the various ways firms can reduce costs and increase manufacturing efficiency, the table herein compares three hypothetical examples representative of real-world cost savings that can be incurred with use of the BioTrak Real-Time Viable Particle Counter in aseptic fill-finish lines.

ROI with Use of the BioTrak Real-Time Viable Particle Counter—Comparison of Three Hypothetical Fill-Finish Manufacturing Lines

	Example 1	Example 2	Example 3
Process Scenario	Typical fill-finish operation running below optimal capacity —Replacing traditional growth-based methods with BioTrak Real-Time Viable Particle Counter contributes to reduced microbiology costs and reduced downtime .	Increased output by a factor of two over Example 1 —BioTrak Real-Time Viable Particle Counter further reduces microbiological costs and downtime as throughput increases. This results in greater ROI and further reduced payback period .	Same output as Example 2 but this line is performing risk mitigations after interventions. These include a needle flush (to avoid nozzle clogging) and vial wasting —BioTrak Real-Time Viable Particle Counter eliminates these costs and thus shows the shortest payback period .
Product & Process Parameters			
COGM (\$/vial)	8	8	8
Current Capacity (vials/month)	500,000	1,000,000	1,000,000
Current Throughput (vials/hour)	4000	4000	4000
Fill-Finish Line Operating Cost (\$/hour)	400	400	400
Interventions for Microbial Monitoring			
Sample Points (#)	4	4	4
Intervention Frequency (int./8 hour shift)	3	3	3
Intervention Duration (mins/int.)	20	20	20
Cost/Microbiology Results	85	85	85
Intervention Risk Mitigation			
Needle Flushing (vials/int.)	0	0	50
Wasted Product (vials/int.)	0	0	35
Impact of Microbiology Interventions			
Interventions/year	563	1125	1125
Microbiology Samples/year	2250	4500	4500
Intervention Downtime Hours/year	188	375	375
Drug Doses Wasted for Risk Mitigation	0	0	95,625
Cost Savings			
Microbiology Costs	\$191,250	\$382,500	\$382,500
Wasted Product	\$-	\$-	\$315,050
Downtime	\$75,000	\$150,000	\$150,000
ROI Metrics			
Annual Costs Savings	\$266,250	\$382,500	\$697,550
Implementation Costs	\$560,000	\$560,000	\$560,000
Payback Period (years)	2.1	1.5	0.8



UNDERSTANDING, ACCELERATED

TSI Incorporated - Visit our website www.tsi.com for more information.

USA Tel: +1 800 874 2811
UK Tel: +44 149 4 459200
France Tel: +33 1 41 19 21 99
Germany Tel: +49 241 523030

India Tel: +91 80 67877200
China Tel: +86 10 8219 7688
Singapore Tel: +65 6595 6388

References

Optimizing the Design and Operation of Fill-Finish using Process Simulation and Scheduling Tools. Demetri Petrides, Charles Siletti, Jose Jimenez, Petros Psanthalas, Yvonne Mannion; Pharmaceutical Engineering, March/April 2011, Vol. 31 No. 2, 1-10

Disposable Technologies for Aseptic Filling: A Case Study. Jan-Zandbergen, Miriam Monge; BioProcess International, June 2006, Disposables Supplement, 48-51.