

These installation instructions cover installing the flow station option to any TSI Controller or Monitor that accepts a flow station input. TSI controllers that have not been modified to accept the flow station input will not work with the flow stations.

NOTE: See the appropriate Installation Instructions to install and wire the controller.

Component List

| Part Number | Qty | Description |
|-------------|-----|------------------------------|
| N/A | 1 | CFM probe sized to duct work |
| 804139 | 1 | Pressure transducer |
| 3001254 | 20' | ¼" pneumatic tubing |

Flow Station Installation

1. Select the mounting location of the flow station. The construction plans normally show the mounting location. If no location is specified, typically the flow station is installed upstream of the damper actuator.

WARNING: Figure 1 gives the minimum straight length duct diameters required for the flow station to operate correctly.

TSI recommends installing the flow station upstream of the damper (before). TSI does not recommend installing the flow station downstream (after) the damper. If the flow station must be placed downstream, a minimum of 4 straight duct lengths between the damper and flow station is required. In addition, the flow station must be rotated 90° (perpendicular) from the damper shaft position.

The minimum straight duct lengths shown are the absolute minimum.

2. Drill a 1¼" hole in the side of the duct work. If probe is longer than 18 inches drill a 5/16" hole directly across from the 1¼" hole (Figure 2).
3. Slide foam gasket onto flow station, and insert into duct work. Insert the flow station through the 1¼" hole, and into the 5/16" hole (if required). On probes 18 inches or longer attach the nut to the threaded end of the flow station (5/16" hole end).
4. Rotate the flow station until the air flow indicator arrow matches the correct direction of air flow.
5. Screw the flow station into place with sheet metal screws (screws not provided by TSI). On 18 inch and longer flow stations tighten the 5/16" nut. The finished installation should look like Figure 2.

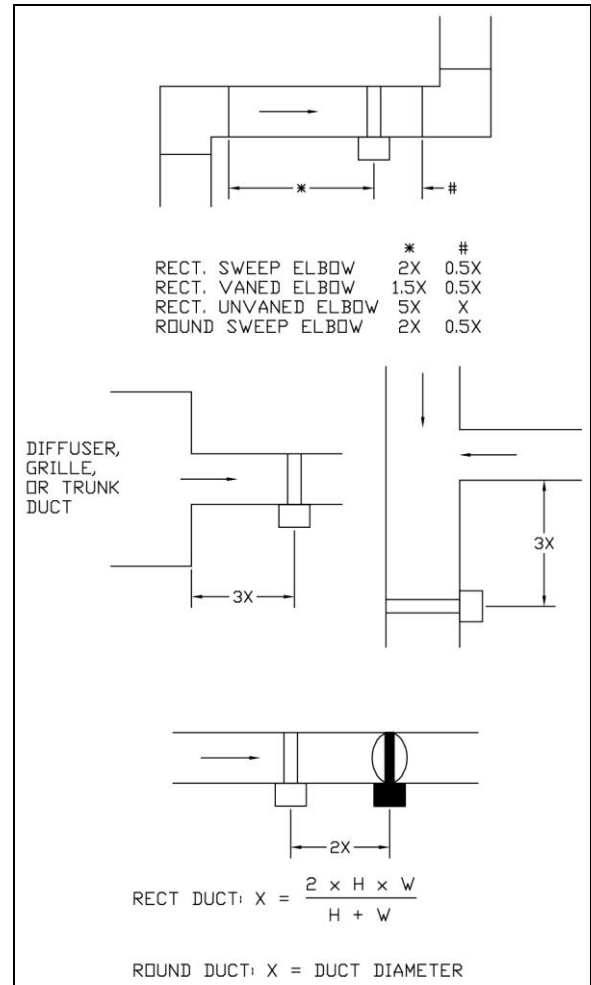

Figure 1: Flow Station Mounting Location

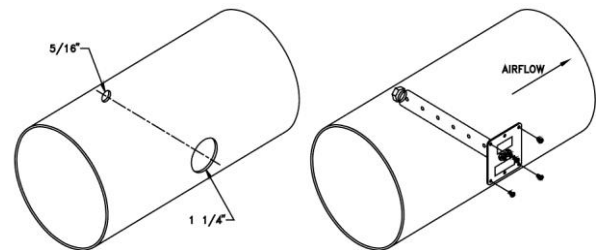

Figure 2: Flow Station Hole Location

- Verify that the jumpers on the pressure transducer are installed correctly, per Figure 3. The default pressure transducer output range is 0 to 0.5 in H₂O.
- Mount the pressure transducer within 10 feet of the flow station. The transducer must be mounted on a wall in the correct position per Figure 4 (screws not provided).

WARNING: Do *not* mount pressure transducer to ceiling, duct work or vibrating surfaces. Preferred mounting location is on the wall nearest the flow station.

- Run two ¼" pneumatic lines (20' included) between flow station and pressure transducer and connect.

| Flow Station | | Pressure Transducer |
|--------------|----|---------------------|
| Total | to | Hi |
| Static | to | Lo |

Double check that the pneumatic tubing is correctly plumbed, firmly seated, and has a tight fit.

- Refer to the wiring diagram for proper transducer wiring (Figure 5). The cable is terminated at the pressure transducer and at the TSI controller or monitor.

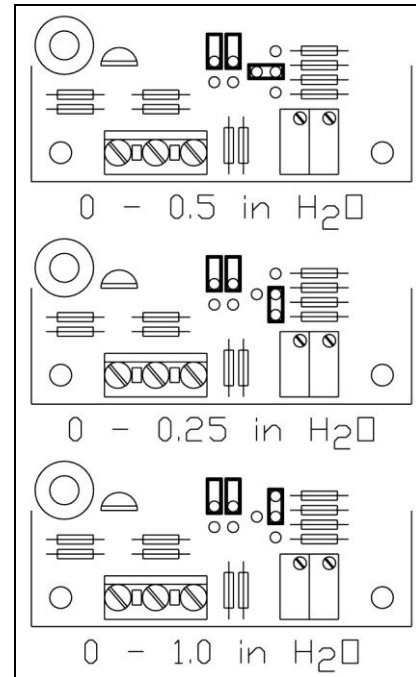

Figure 3: Pressure Transducer Jumpers

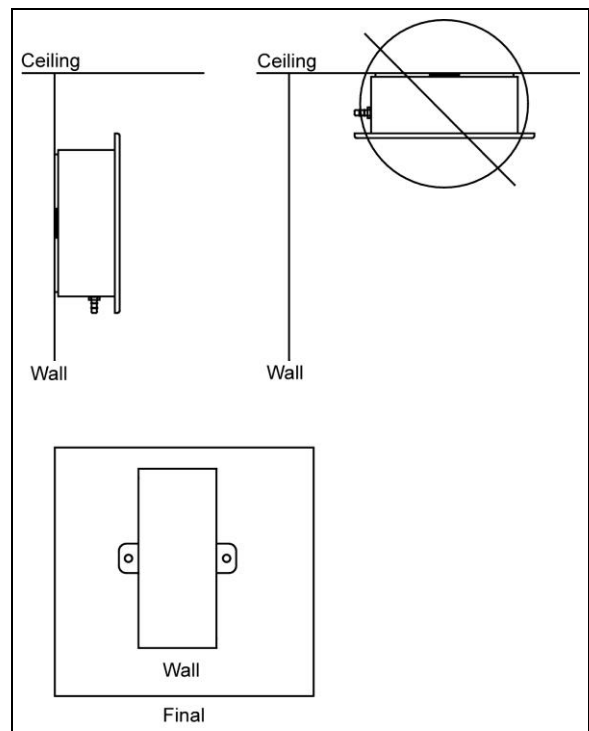

Figure 4: Pressure Transducer Mounting

Wiring the Pressure Transducer

WARNING: Do *not* connect more than 24 VAC to any terminal.

Do *not* apply voltage to the RS-485 output, analog output, or control output of the TSI device. Severe damage may occur if voltage is applied.

WARNING: Each damper/actuator and flow station has a separate transformer that must be installed. Do *not* wire more than one device per transformer.

Wire the transducer to the FLOW INPUT terminals on the TSI controller, per Figure 5. Refer to the Installation Instructions for the TSI controller to determine the correct terminals.

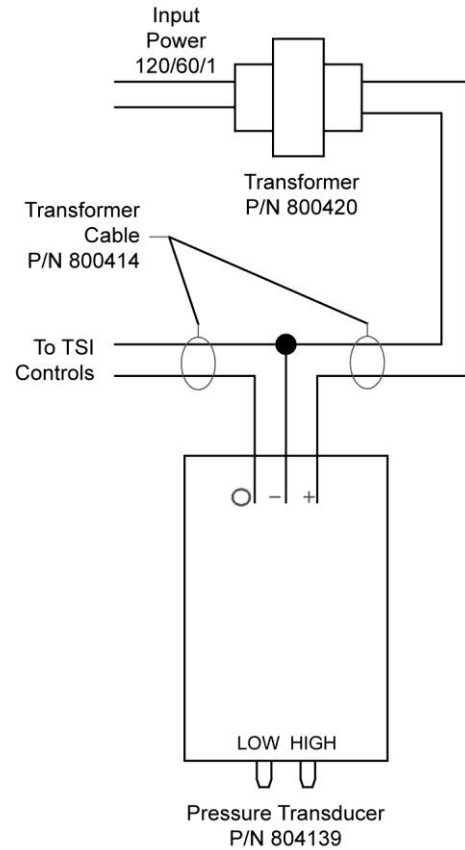

Figure 5: Transducer Wiring

This concludes the installation of the flow station. If you need assistance on installing the controller, see the appropriate Installation Instructions. If you need further assistance installing the system, call TSI Customer Service at 651-490-2811 or 800-874-2811.



UNDERSTANDING, ACCELERATED

TSI Incorporated – Visit our website www.tsi.com for more information.

| | | | |
|---------|-----------------------|-----------|-----------------------|
| USA | Tel: +1 800 874 2811 | India | Tel: +91 80 67877200 |
| UK | Tel: +44 149 4 459200 | China | Tel: +86 10 8251 6588 |
| France | Tel: +33 491 11 87 64 | Singapore | Tel: +65 6595 6388 |
| Germany | Tel: +49 241 523030 | | |