



® Knowledge Beyond Measure.

# Scanning Mobility Particle Sizer™ Particle Sizer™ Spectrometer

Model 3938



## Highly accurate, real-time nanoparticle sizing systems you can rely on for years.

The TSI Scanning Mobility Particle Sizer™ (SMPS™) spectrometer is the standard for measuring the size distribution of nanoparticles in air. The method is described in the ISO standard 15900:2020 and hundreds of scientific publications from national metrology institutions and other leading academic and industrial researchers. The results are independent of the refractive index of the solid or liquid aerosol, and have a high degree of absolute sizing accuracy and measurement repeatability. TSI's model 3938 is the 3rd generation of SMPS; trusted by researchers for over 30 years.

### Features and Benefits

- High resolution nanoparticle sizing with discreet size channels and single particle counting
- Independent of optical properties of the aerosol
- Wide size range: from 1 nm to 1,000 nm depending on configuration
- High resolution data: 128 channels/decade for up to 384 total possible channels
- Dynamic concentration range up to  $10^7$  particles/cm<sup>3</sup>
- Fast measurements: <10 second scans
- Component design for maximum flexibility with a selection of five Condensation Particle Counters (CPCs), four Differential Mobility Analyzers (DMAs), and traditional or non-radioactive neutralizer
- Easy setup with tool-free installation and auto-discovery of components
- ISO 15900:2020 compliant
- PC or touch screen control†

† A computer is needed for wide-range scans and operation of the 1nm SMPS

### Applications

- Environmental monitoring and atmospheric research
- Nucleation and new particle formation studies
- Combustion and engine exhaust studies
- Indoor air quality measurements
- Inhalation toxicology studies
- Nanomaterial research and synthesis



# Proven Technology for Highly Resolved Particle Sizing

## Sizing Nanoparticles with Differential Mobility Analysis

This method is based on the physical principle that the ability of a particle to traverse an electric field (electrical mobility) is fundamentally related to particle size — no size calibration is necessary (first principle measurement).

TSI's Scanning Mobility Particle Sizer™ Spectrometer (SMPS™) measures the size distribution and concentration of particles in the size range of 1 nm to 1 μm using differential mobility analysis. In a Differential Mobility Analyzer (DMA), an electric field is created and the airborne particles drift in the DMA according to their electrical mobility. Particle size is then calculated from the mobility distribution. This method is described in the ISO 15900:2020 guidelines and TSI's SMPS™ and DMAs comply with this standard. Additionally, the Wide-Range DMA 3083 complies with CEN/TS 17434:2020.

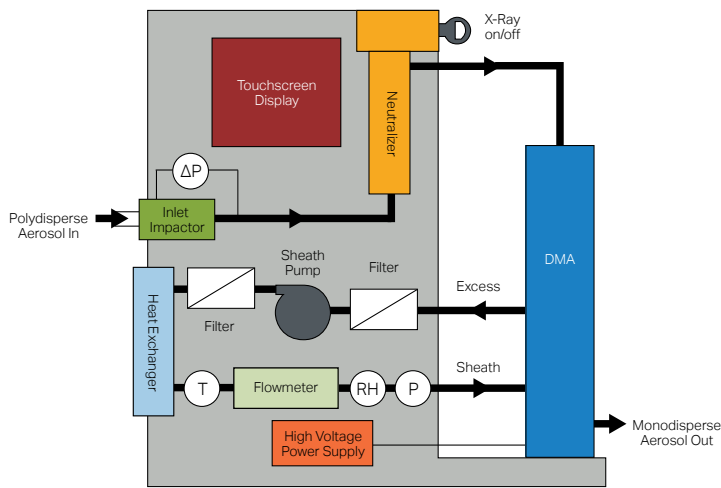

The technology used in the SMPS Spectrometer is protected by US Patents 4,790,650 and 5,118,959

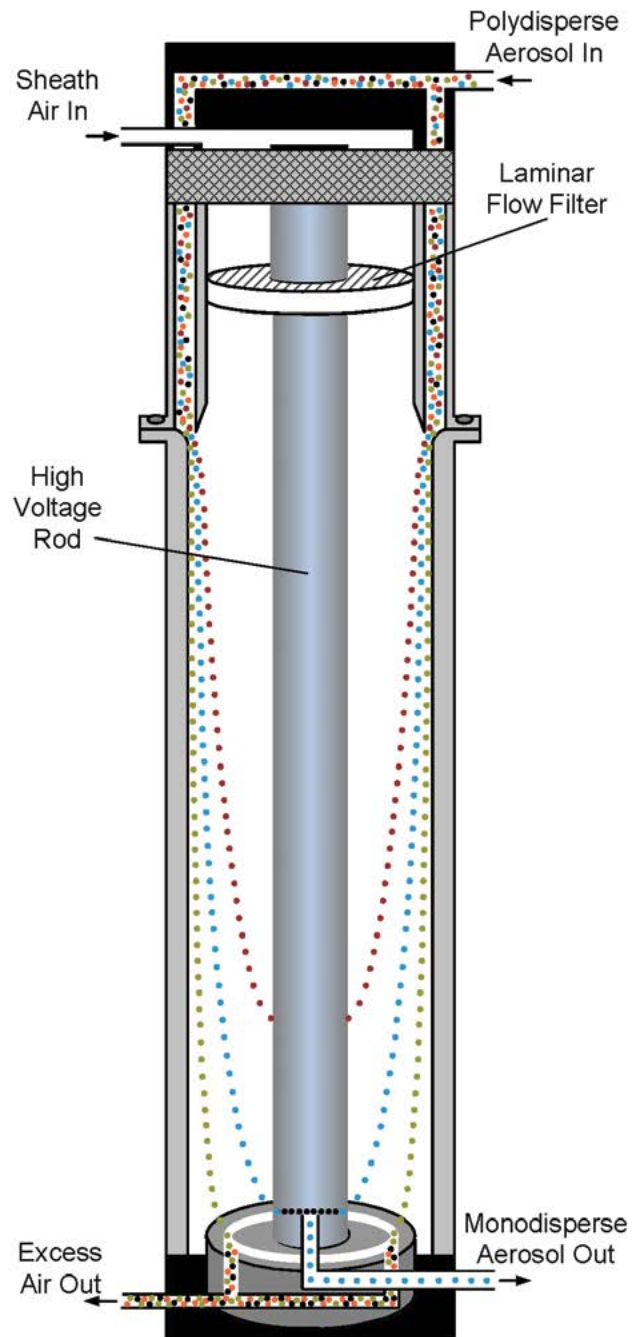

DMA 3081A flow schematic

# A Broad Range of Options to Meet Your Measurement Needs

## Differential Mobility Analyzers (DMAs)

DMAs are the core of the SMPS™, selecting monodisperse size fractions of the nanoparticles to be quantified in the CPCs. The Electrostatic Classifier 3082 identifies the attached DMA model automatically.



- Long Differential Mobility Analyzer 3081A: This classic DMA has been relied upon by aerosol researchers for over 40 years. Data from the DMA model 3081A is well known to be precise, repeatable, and comparable to results measured by the luminaries in the field of aerosol science.
- Nano Differential Mobility Analyzer 3085A: Improves size resolution over the particle size range of 2.5 – 150 nm and also features increased nanoparticle transmission efficiency through the DMA.
- 1nm Differential Mobility Analyzer 3086: Expands high resolution measurements down to 1 nm. Optimized for minimal diffusion losses and improved resolution over the size range of 1-50 nm.
- Wide-Range Differential Mobility Analyzer 3083: Enables wide-range scanning, from 10-800nm in a single scan. Compliant with CEN/TS 17434:2020 for monitoring ambient ultrafine particles.

## Aerosol Neutralizers

The neutralizers utilize bipolar diffusion charging to bring the aerosol to a defined, steady-state charge distribution.

- Aerosol Neutralizer 3077A: The traditional <sup>85</sup>Kr neutralizers have been used in the industry for decades.
- Advanced Aerosol Neutralizer 3088: Provides a nonradioactive option, and features virtually identical sizing to radioactive sources when used in a sizing system with built-in power from the classifier for easy integration.

## Condensation Particle Counters (CPCs)

CPCs are the single-particle counters used in SMPS™ to quantify the nanoparticles in each monodisperse size fraction classified in the DMA.

TSI's first CPC was released 1968. Today TSI has five SMPS™-compatible CPCs to match the application's need.



- Butanol CPCs: The 4th generation features extended single particle counting range superior data accuracy and signal control for measuring particles down to 2.5 nm.
- Water-based CPC: Delivers accurate concentrations of particles in gases while making use of safe, eco-friendly and easily available distilled water. The 3rd generation has a selectable cut-off particle size and can detect sub-2 nm particles.
- 1 nm CPC: The Nano Enhancer 3757 uses diethylene glycol as a working fluid to allow the growth of particles from 1 nm. Paired with the CPC 3750, the 1 nm CPC system can measure concentrations up to 300,000 particles/cm<sup>3</sup>.



## Software

Aerosol Instrument Manager™ software for SMPS is an easy-to-use tool to control the hardware settings, collect, visualize and export the data. For the application of ambient air monitoring, a monitoring-specific software package is available.

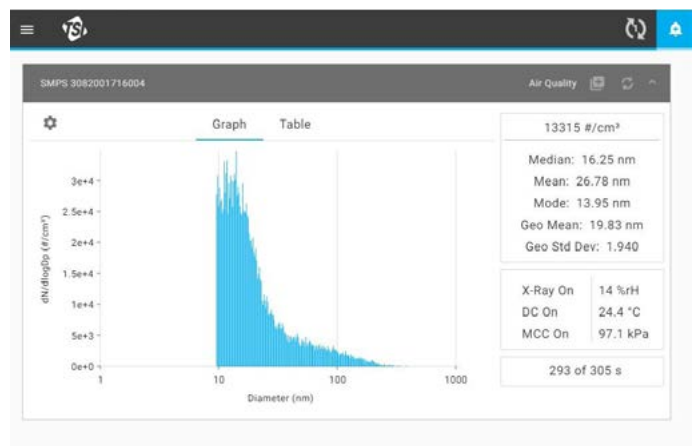

## Specifications

# Scanning Mobility Particle Sizer™

## Model 3938

Refer to separate product sheets for descriptions and specifications of individual components

### General SMPS™ Settings and Requirements

Aerosol Flow Rate	0.2 to 5 L/min, user-adjustable
Sheath Flow Rate	2 to 30 L/min, user-adjustable
Working Fluid	n-butyl alcohol (butanol), distilled water, diethylene glycol (depends on CPC)

### Operating and Aerosol Inlet

Temperature	10 to 40°C
Humidity	0 to 90%, noncondensing
Pressure	70 to 125 kPa

### DMA Voltage - Negative Standard

308202	Dual voltage version optional; included with 3938E57, 3938EL57, 3938E89, 3938EL89
--------	-----------------------------------------------------------------------------------

### Data Acquisition

Internal memory for up to two weeks† or continuous with PC.

### Aerosol Neutralizer Options - Ordered Separately

3077	74 MBq (2 mCi), <sup>85</sup> Kr 1/2 life 10.8-year
3077A	370 MBq (10 mCi), <sup>85</sup> Kr 1/2 life 10.8-year
3088	Soft X-ray <9.5 keV ~8,760 operating hours
6005931	Lead shielding column for 3077/3077A

### Accessories

3750200	Sampling System for Atmospheric Aerosol
RHT3000	Aerosol Humidity & Temperature Sensor

### Included Accessories

Set of three single-stage, inlet impactors.

Conductive tubing.

Flow equalizer.

### Concentration Range

1 to 10<sup>7</sup> particles/cm<sup>3</sup>. The upper end of concentration specification is determined by Aerosol Neutralizer's specifications

### Measurement Time

<10 to 600 s selectable

### Particle Resolution

128 channels/decade for up to 384 total possible channels

### Communication Interfaces

Embedded touch-display.

RS-232 for CPC to Classifier.

USB, and Ethernet for Classifier to PC.

USB type B for external memory drives

### Power Requirements

3750 CPC	200 W
3752/6/7	335 W
3789 WCPC	200 W
3082	200 W

### Dimensions (HWD/Weight)

3081A	61 × 8 × 8 cm / 5.4 kg
3085A	21 × 10 × 10 cm / 2.2 kg
3086	19 × 10 × 10 cm / 2 kg
3083	47 × 13 × 13 cm / 8.5 kg
3082	40 × 28 × 40 cm / 14.2 kg
3750	27.5 × 18.3 × 29.9 cm / 6.6 kg
3752	30.0 × 30.3 × 34.3 cm / 9.1 kg
3756	30.1 × 28.1 × 35.4 cm / 9.1 kg
3757	33.2 × 28.1 × 36.3 cm / 9.1 kg
3789	31 × 18 × 40 cm / 8 kg

CPC Working Fluid	Particle Size Range (nm)	Model #	CPC	DMA	
Butanol	10* to 1,000	3938L50	3750	3081A	
		3938L52	3752		
		3938L56	3756		
	2.5 to 150	3938N56	3756	3085A	
		4 to 150 and 10* to 1,000	3938NL52	3752	3085A and 3081A
		2.5 to 150 and 10* to 1,000	3938NL56	3756	
Diethylene Glycol and Butanol	10 to 800	3938W50-CEN***	3750-CEN	3083	
	1 to 50	3938E57	3757-50	3086	
1 to 50 and 10* to 1,000	3938EL57	3086 and 3081A			
Water	10* to 1,000	3938L89	3789	3081A	
	2.5 to 150	3938N89		3085A	
	2.2** to 50	3938E89		3086	
	2 to 150 and 10* to 1,000	3938NL89		3081A and 3085A	
	2.2** to 50 and 10* to 1,000	3938EL89			3086 and 3081A
	10 to 800	3938W89		3789	3083

Number of total size channels varies by configuration; spans over 384 channels from 1 nm to 1,000 nm collectively. SMPS™ model# consists of the family model number ('3938'), followed by the letter identifying the DMA model(s) ('L', 'N', 'E', 'W', 'NL', 'EL'), and the last two digits of the CPC model (37XX), or in the case of the 3750-CEN, the last two digits plus the suffix (i.e. 50-CEN).

Specifications reflect typical performance and are subject to change without notice.

Aerosol Instrument Manager, TSI and the TSI logo are registered trademarks, and Scanning Mobility Particle Sizer and SMPS are trademarks of TSI Incorporated in the United States and may be protected under other country's trademark registrations..

\* Low end of particle size range determined by DMA 3081A specifications.  
\*\* Lower end of WCPC in standard configuration is 2.2 nm (sucrose aerosol). Cut-off particle size can be adjusted by customer to lower values.

\*\*\* If desired, this system may be purchased as 3938W50 (i.e. without the standard TROPOS calibration included), and that calibration obtained separately.

† A computer is needed for 3938Exx SMPS systems, and 3938Wxx SMPS systems in wide-range scanning mode.



Knowledge Beyond Measure.

TSI Incorporated - Visit our website [www.tsi.com](http://www.tsi.com) for more information.

<b>USA</b>	Tel: +1 800 874 2811	<b>India</b>	Tel: +91 80 67877200
<b>UK</b>	Tel: +44 149 4 459200	<b>China</b>	Tel: +86 10 8219 7688
<b>France</b>	Tel: +33 1 41 19 21 99	<b>Singapore</b>	Tel: +65 6595 6388
<b>Germany</b>	Tel: +49 241 523030		