

MODEL 8692 TO MODEL 8630

REMOTE AUDIBLE ALARM

INSTALLATION INSTRUCTIONS

The purpose of these instructions is to guide the installer through the installation of the TSI Model 8692 Remote Audible alarm. These instructions cover the PRESSURA™ line (Model 8630) of products.

The remote audible alarm must be wired per Figure 1, 2 or 3. Wire should be 24 AWG or larger (not supplied by TSI). Any modification to the wiring may damage the alarm or Digital Interface Module.

Installation

The remote audible alarm is designed to mount to a 2 × 4 single gang electrical box. Install the electrical box where the remote audible alarm is to be located.

Use Figure 1, wiring diagram, when installing just a Model 8692 Remote Audible Alarm to a Digital Interface Module.

Use Figure 2, wiring diagram, when installing both a Model 8692 Remote audible alarm and Model 8694 Room Pressure Alarm to a Digital Interface Module.

Use Figure 3, wiring diagram, when installing multiple Model 8694 Room Pressure Alarms and one Model 8692 Remote Audible Alarm.

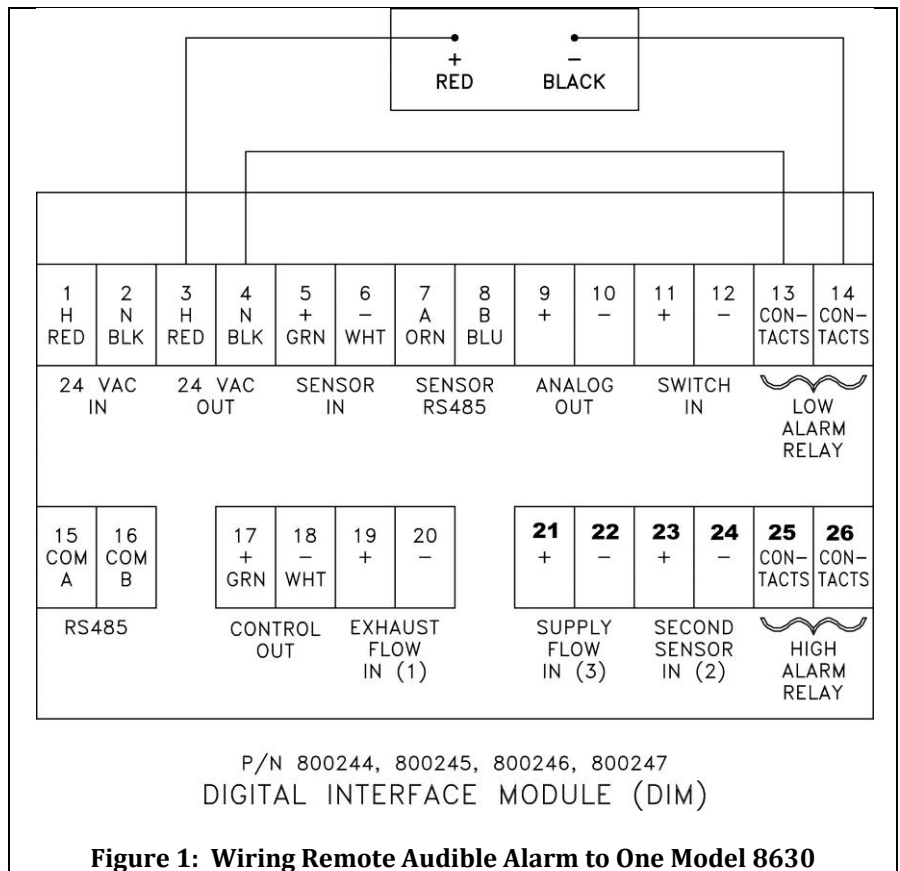

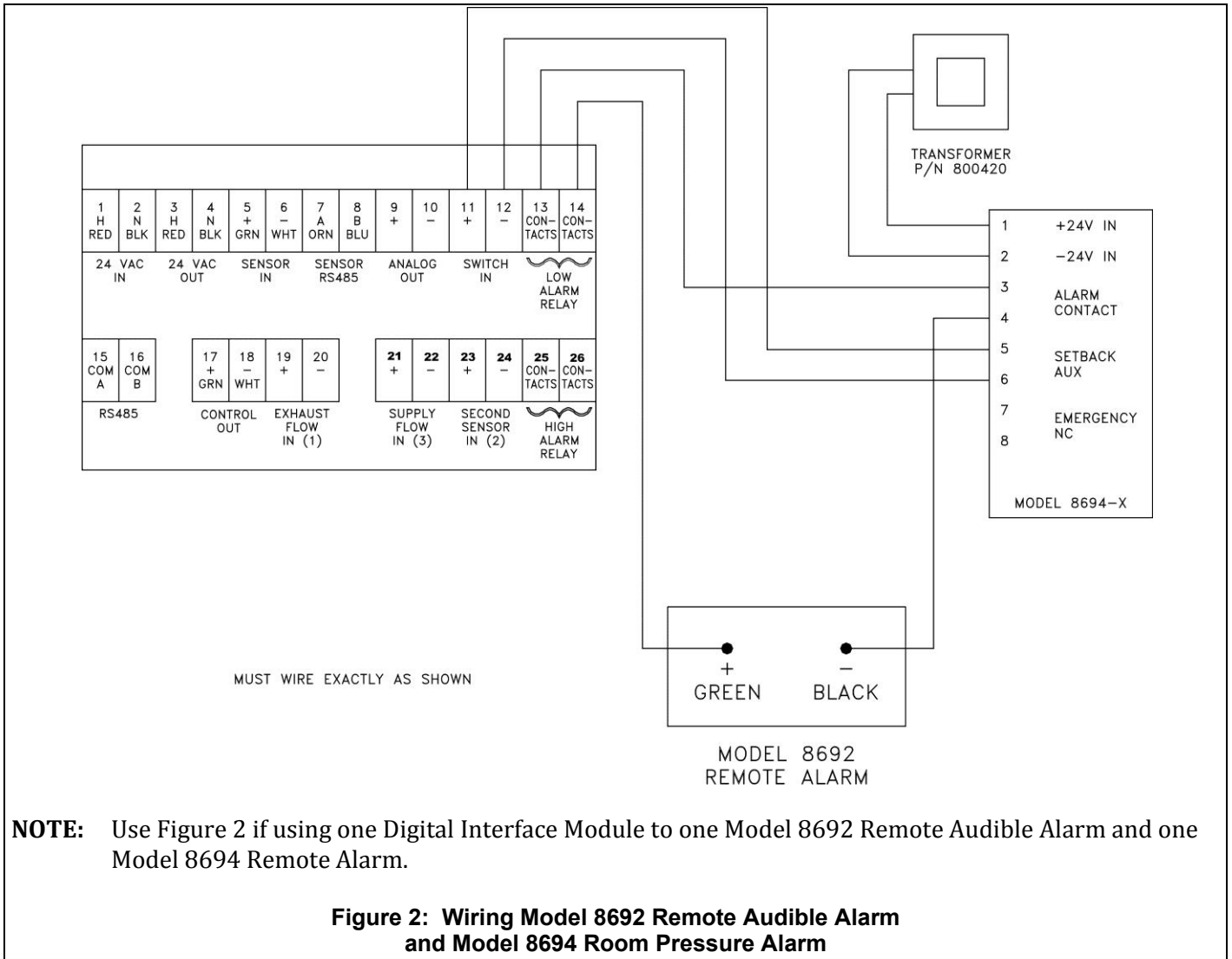

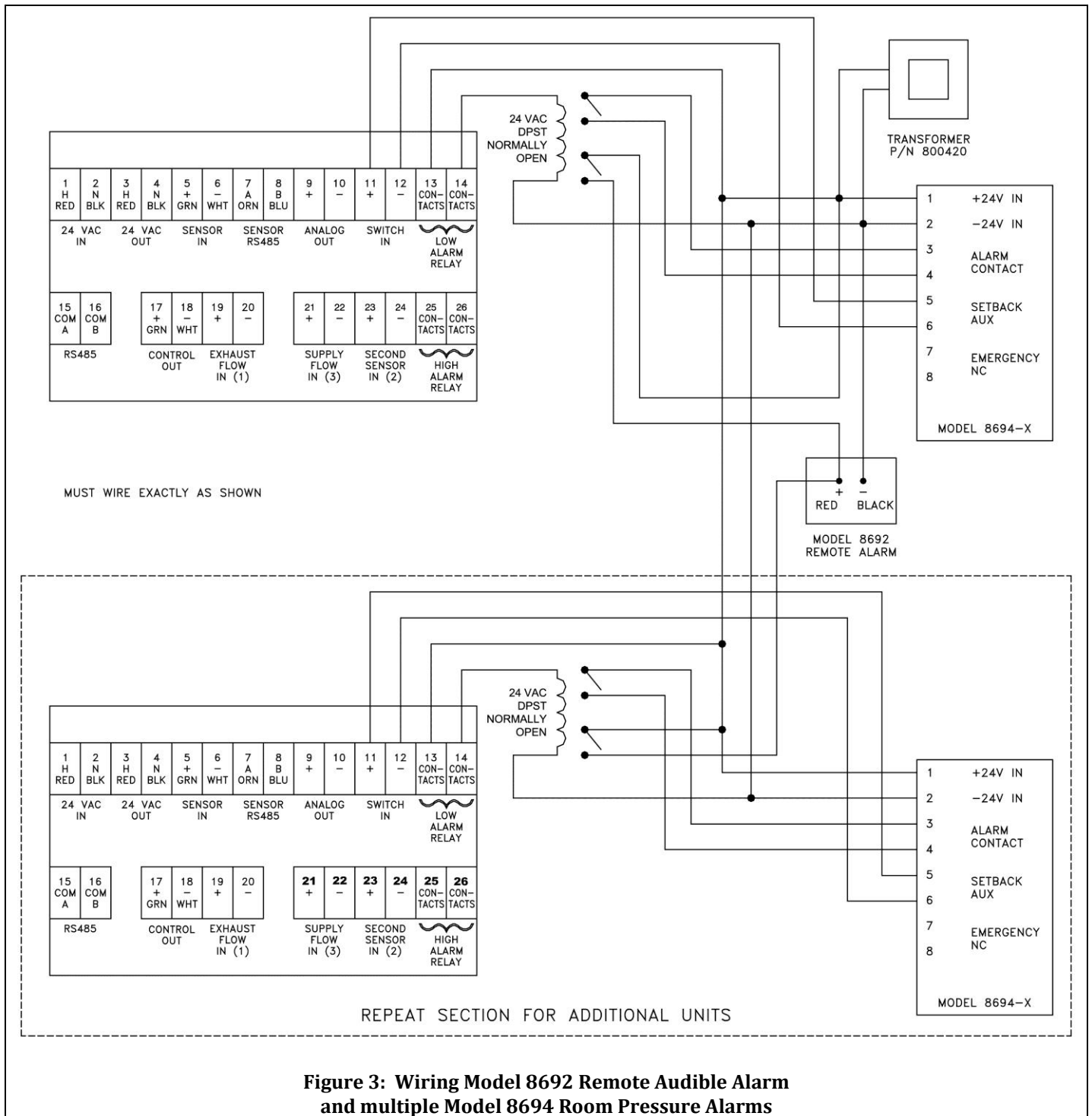

Figure 3: Wiring Model 8692 Remote Audible Alarm and multiple Model 8694 Room Pressure Alarms



UNDERSTANDING, ACCELERATED

TSI Incorporated - Visit our website www.tsi.com for more information.

USA Tel: +1 800 874 2811
 UK Tel: +44 149 4 459200
 France Tel: +33 491 11 87 64
 Germany Tel: +49 241 523030

India Tel: +91 80 67877200
 China Tel: +86 10 8219 7688
 Singapore Tel: +65 6595 6388