

UL FIRE LISTING FOR ROOM PRESSURE DEVICES

APPLICATION NOTE LC-104

TSI has received UL fire rating approval for room pressure devices. This means the TSI sensor can penetrate any wall and not violate the fire rating. Figure 1 shows the fire listing for concrete and concrete block walls. Figure 2 shows the fire listing for gypsum wallboard (sheetrock).

XHEZ
Through-Penetration
Firestop System

System No. WJ2016
F Rating-2 Hr
T Rating-1 Hr

December 13, 1994
(WJ2016-A card)

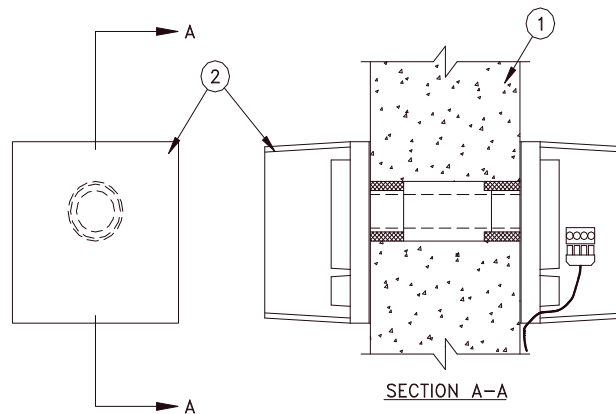

(Cont. on WJ2016-B card)
C1M/0267573
187

Underwriters Laboratories Inc.®

XHEZ
Through-Penetration
Firestop Systems

December 13, 1994
(WJ2016-B card)
(Cont. from WJ2016-A card)

System No. WJ2016

- Wall Assembly**—Min 6 in. thick reinforced lightweight or normal weight (100-150 pcf) concrete. Wall may also be constructed of any UL Classified **Concrete Blocks***. Max dia. of opening is 2-1/4 in.
See **Concrete Blocks** (CAZT) category in the Fire Resistance Directory for names of manufacturers.
- Through Penetrating Products***—Air balancing device consisting of two pressure sensor boxes, a sensor element, cross tube, 4 conductor sensor cable and two intumescent insert rings. Device installed per manufacturer's instructions in a 2-1/4 in. dia. opening drilled through wall assembly.

TSI Inc.

*Bearing the UL Classification Marking

C1M/0267574
188

Underwriters Laboratories Inc.®

Figure 1: Concrete and Concrete Block Walls



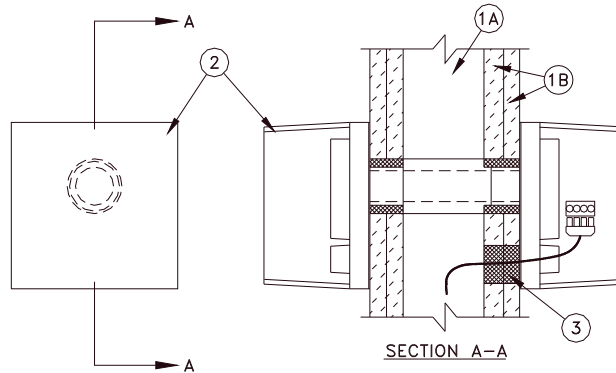

(Cont. on WL2080-B card)
C1M/0267571
199

Underwriters Laboratories Inc. ®

System No. WL2080

(WL2080-B card)
(Cont. from WL2080-A card)

1. **Wall Assembly**—The fire-rated gypsum wallboard/stud wall assembly shall be constructed of the materials and in the manner specified in the individual U300 or U400 Series Wall and Partition Designs in the UL Fire Resistance Directory and shall include the following construction features:
 - A. **Studs**—Wall framing may consist of either wood studs or steel channel studs. Wood studs to consist of nom 2 by 4 in. lumber spaced 16 in. OC. Steel studs to be min 3-5/8 in. wide and spaced max 24 in. OC.
 - B. **Wallboard, Gypsum***—Two layers of nom 5/8 in. thick gypsum wallboard, as specified in the individual Wall and Partition Design. Max dia. of opening is 2-1/4 in.
2. **Through Penetrating Products***—Air balancing device consisting of two pressure sensor boxes, a sensor element, cross tube, 4 conductor sensor cable and two intumescent insert rings. Device installed per manufacturer's instructions in a 2-1/4 in. dia. opening cut through both sides of wall assembly.
TSI Inc.
3. **Fill, Void or Cavity Material—Putty**—Min 1 in. thickness of fill material, supplied with air balancing device, applied within the annulus to fill a 3/4 in. dia. opening drilled for sensor cable.

*Bearing the UL Classification Marking

C1M/0267572
200

Underwriters Laboratories Inc. ®

Figure 2. Gypsum Wallboard (Sheetrock) Studwall



UNDERSTANDING, ACCELERATED

TSI Incorporated – Visit our website www.tsi.com for more information.

| | | | |
|----------------|-------------------------------|------------------|------------------------------|
| USA | Tel: +1 800 874 2811 | India | Tel: +91 80 67877200 |
| UK | Tel: +44 149 4 459200 | China | Tel: +86 10 8251 6588 |
| France | Tel: +33 4 91 11 87 64 | Singapore | Tel: +65 6595 6388 |
| Germany | Tel: +49 241 523030 | | |