

Vertical Sash Sensor for FHC50



P/N 800925, 800953

Installation Instructions

NOTICE

This document serves as a guide for the installation of the 800925 and 800953 Vertical Sash Sensors for use with the Model FHC50 Fume Hood Controller. Please read these instructions thoroughly before beginning installation.

The Model FHC50 Fume Hood Controller is designed to accommodate fume hoods with up to three vertically-moving sashes, with each sash connected to a Vertical Sash Sensor. The Vertical Sash Sensor is designed to be mounted to the fume hood sash counter-weight cable system.

Included Parts

Description	Qty
Vertical Sash Sensor w/12 ft Electrical Cable	1
800925: 50" Sash Sensor Cable, 10 k-Ω	
800953: 120" Sash Sensor Cable, 5 k-Ω	
Cable Clamp Hook	1
Cable Clamp Wheel	1
Shoulder Screw (8-32 x 3/16")	1
Thumb Screw (10-32 x 1/2")	1
Installation Instructions	1

Vertical Sash Sensor Installation

WARNING

For implementations with multiple sashes and multiple Vertical Sash Sensors, installation and wiring must be completed as described in these instructions. Failure to mount, install, and wire the Vertical Sash Sensors correctly can result in poor fume hood control functionality and loss of containment.

For fail safe operation, install the Vertical Sash Sensor so that the Sash Sensor Cable extends as the sash is closing and retracts as the sash is opening, as detailed later in this document. This ensures that if a Sash Sensor Cable breaks or becomes disconnected, the Vertical Sash Sensor will respond as if the sash is open.

The Vertical Sash Sensor is designed to be mounted to the fume hood sash counter-weight cable system.

The P/N 800925 Vertical Sash Sensor Cable has a travel of approximately 50 in (1.3 m) and the P/N 800953 Vertical Sash Sensor Cable has a travel of approximately 120 in (3.0 m). **DO NOT** exceed the maximum sash travel or the Vertical Sash Sensor will be damaged.

Prepare the Vertical Sash Sensor—Attach Cable Clamp Parts

1. Attach the Cable Clamp Hook and Cable Clamp Wheel to the Vertical Sash Sensor using the Philips Shoulder Screw (Figure 1). Slide the Shoulder Screw through the eyelet on the end of the Sash Sensor string, through the Cable Clamp Hook, and fully tighten to the Cable Clamp Wheel.
2. Insert the Thumb Screw into the top of the Cable Clamp Hook, but **DO NOT** tighten all the way (Figure 1). Leaving the Thumb Screw in this position will allow for easy adjustment of the Cable Clamp Wheel when attaching to the sash counter-weight cable.

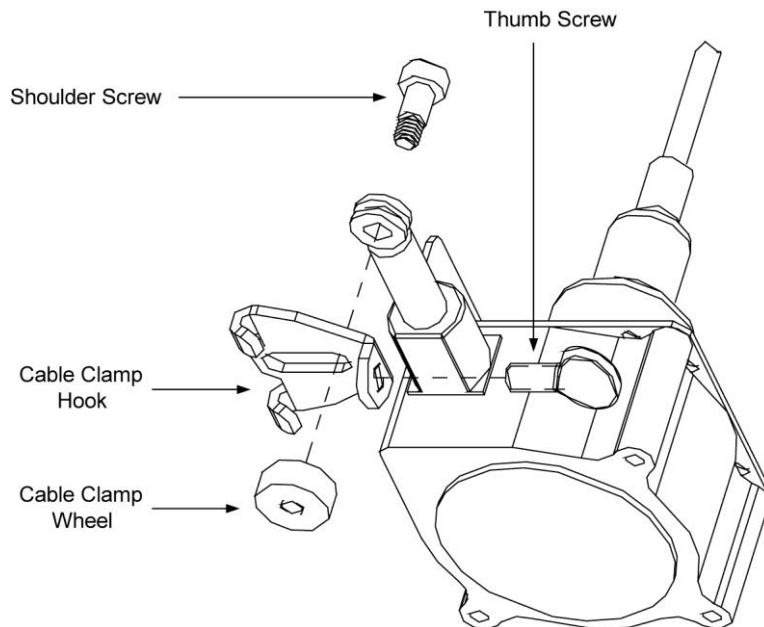

Figure 1: Attaching Cable Clamp Parts to Vertical Sash Sensor

Selecting the Vertical Sash Sensor Mounting Location

The Vertical Sash Sensor is typically mounted on top of the fume hood where there is access to the sash counter-weight cables, which connect the sash window to the counter-weight (Figure 2, option A or B). Alternatively, the Vertical Sash Sensor may be connected to the sash window (Figure 2, option C).

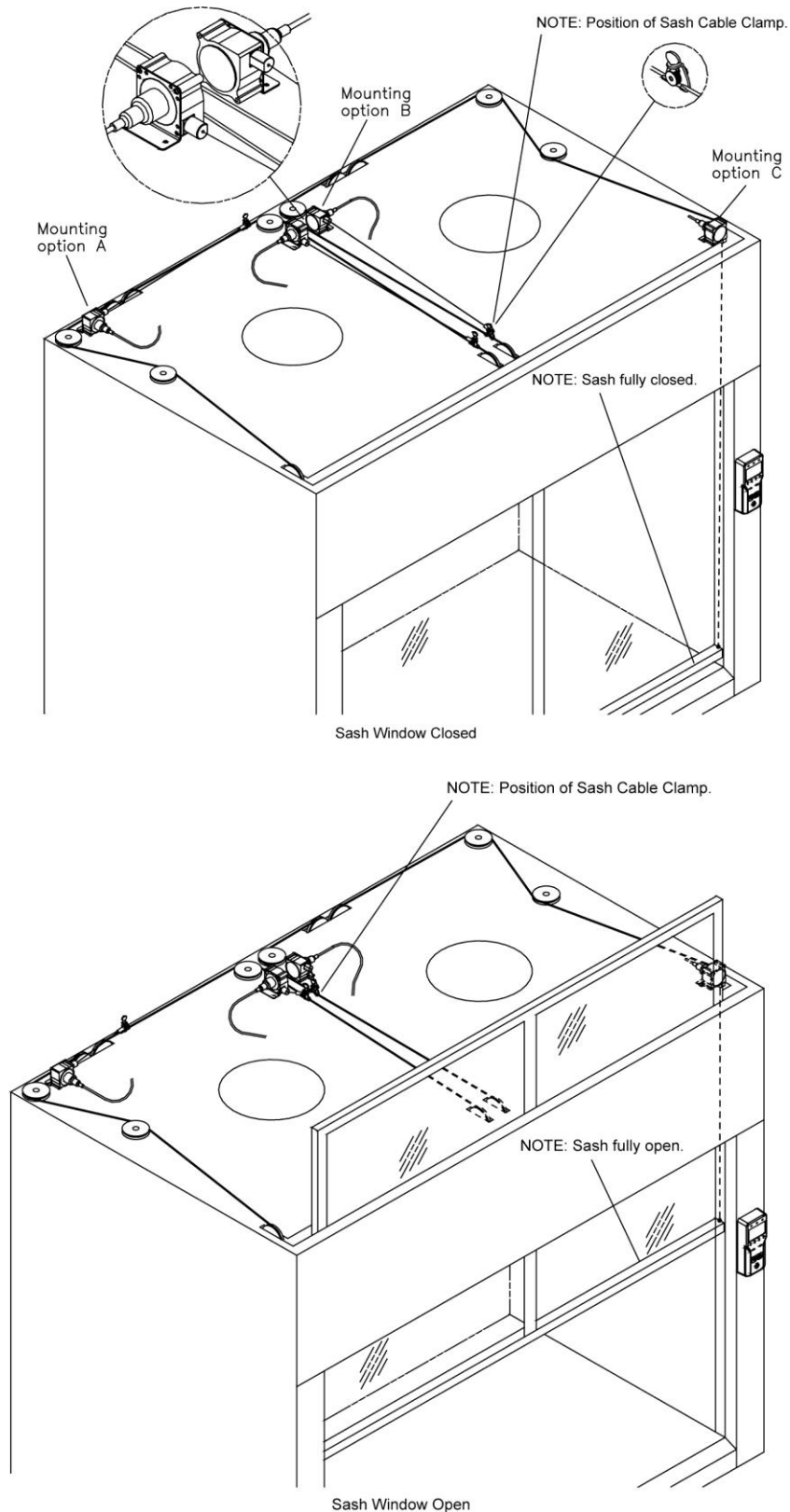

Figure 2: Example of Vertical Sash Sensor Mounting Location

1. Close the fume hood sash completely.
2. Locate a straight run of sash counter-weight cable on top of the fume hood, which has a distance between pulleys that is greater than the sash window travel from fully closed to fully open 100%.
3. Mark the sash counter-weight cable with a piece of tape or marker (Figure 3).

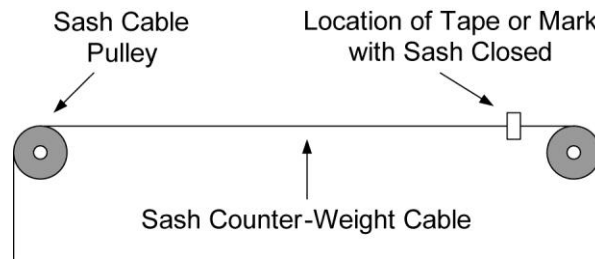

Figure 3: Mark the Sash Counter-Weight Cable

4. Open the sash 100%, and verify that the tape or mark travels along a straight line without passing through a pulley or other obstruction (Figure 4). If the fume hood has a sash window stopper, make sure to release the stopper so the sash can be opened 100%. If the travel on this run of sash counter-weight cable is acceptable, the Cable Clamp will be secured to this taped or marked location.

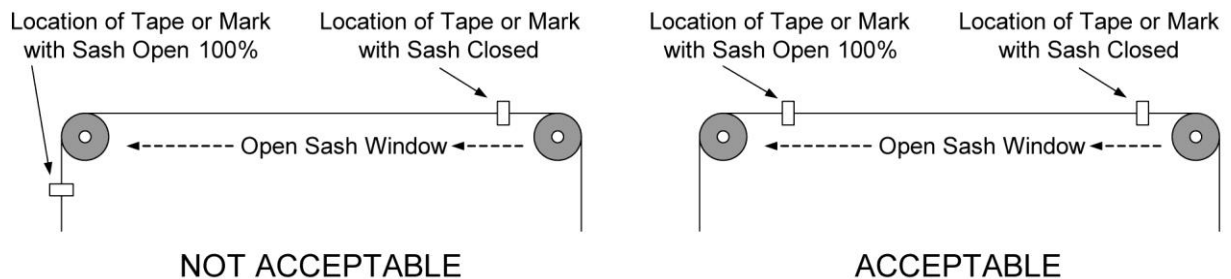

Figure 4: Verify Tape or Mark Travel on Sash Counter-Weight Cable

Vertical Sash Sensor Mounting

For fail safe operation, install the Vertical Sash Sensor so that the Sash Sensor Cable extends as the sash is closing and retracts as the sash is opening (Figure 5). This ensures that if a Sash Sensor Cable breaks or becomes disconnected, the Vertical Sash Sensor will respond as if the sash is open.

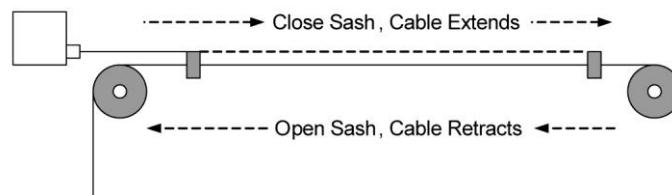

Figure 5: Mounting for Fail Safe Operation

NOTICE

Multiple Vertical Sash Sensors may be mounted to the same fume hood, each connected to a different vertical sash window and counter-weight cable. Each Vertical Sash Sensor must be installed so that the Sash Cable extends as its sash is closing and retracts as its sash is opening. Failure to install correctly can result in poor fume hood control functionality and loss of containment.

1. Mount the Vertical Sash Sensor to the fume hood frame using two screws (not provided). (Figure 6).
2. Note that the mounting L-bracket attached to the Vertical Sash Sensor can be rotated on its body for maximum mounting flexibility. Remove the three screws on the side of the Vertical Sash Sensor, rotate the mounting L-bracket to the desired position, and re-apply screws.
3. The Vertical Sash Sensor must be mounted so that the Sensor Cable extends at little or no angle from the body of the Vertical Sash Sensor, and so there is no interference with any moving parts or objects.

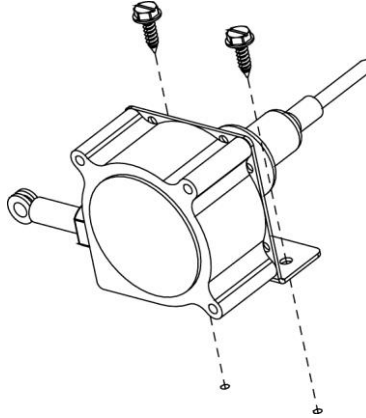

Figure 6: Vertical Sash Sensor Mounting

4. Attach the Vertical Sash Sensor Cable Clamp to the sash counter-weight cable in the previously taped or marked location. Route the sash counter-weight cable through the Cable Clamp Hook, and fully tighten the Thumb Screw to secure the sash counter-weight cable to the Cable Clamp (Figure 7).

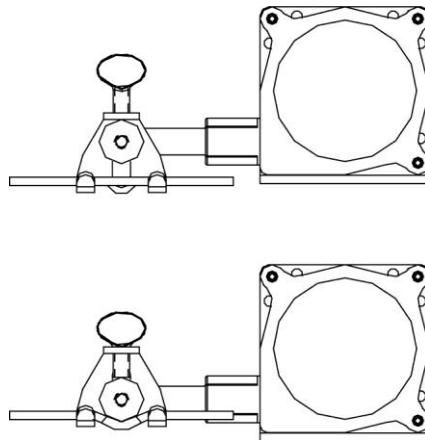

Figure 7: Attaching Cable Clamp to the Sash Counter-Weight Cable

Vertical Sash Sensor Wiring

WARNING

For implementations with multiple sashes and multiple Vertical Sash Sensors, installation and wiring must be completed as described in these instructions. Failure to mount, install, and wire the Vertical Sash Sensors correctly can result in poor fume hood control functionality and loss of containment.

After mounting the Vertical Sash Sensor and attaching the Cable Clamp to the sash counter-weight cable, it must be wired to the FHC50 Fume Hood Controller. The FHC50 Fume Hood Controller is designed to accommodate fume hoods with up to three vertically-moving sashes, with each sash connected to a Vertical Sash Sensor. Route the Vertical Sash Sensor Electrical Cable to the FHC50 Fume Hood Controller location and make connections as described below.

NOTICE

When wiring multiple Vertical Sash Sensors together, the electrical wiring must be connected in series as described in the following section. Connect the wires in series using a wire nut or other preferred method.

Wire the Vertical Sash Sensor to the FHC50 Fume Hood Controller as shown (Figures 8 and 9).

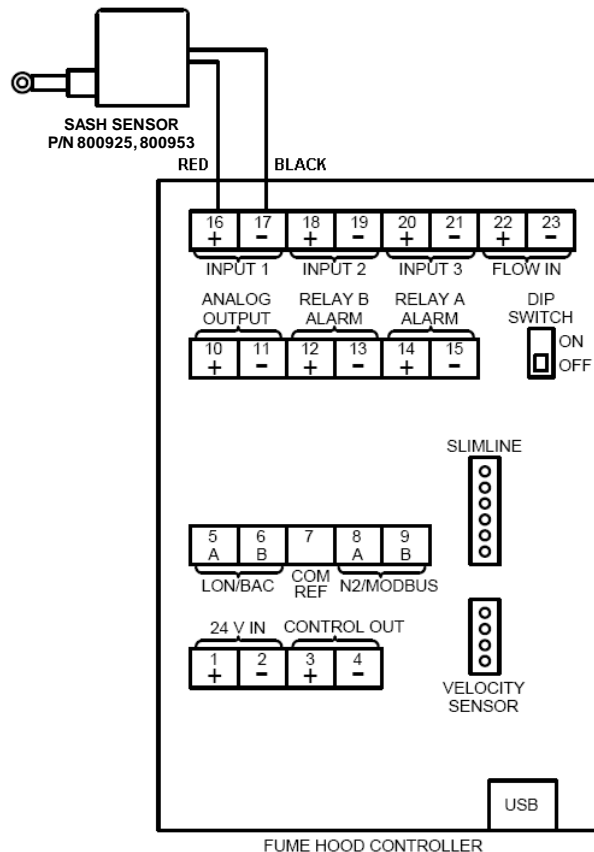

Figure 8: Wiring with One Vertical Sash Sensor

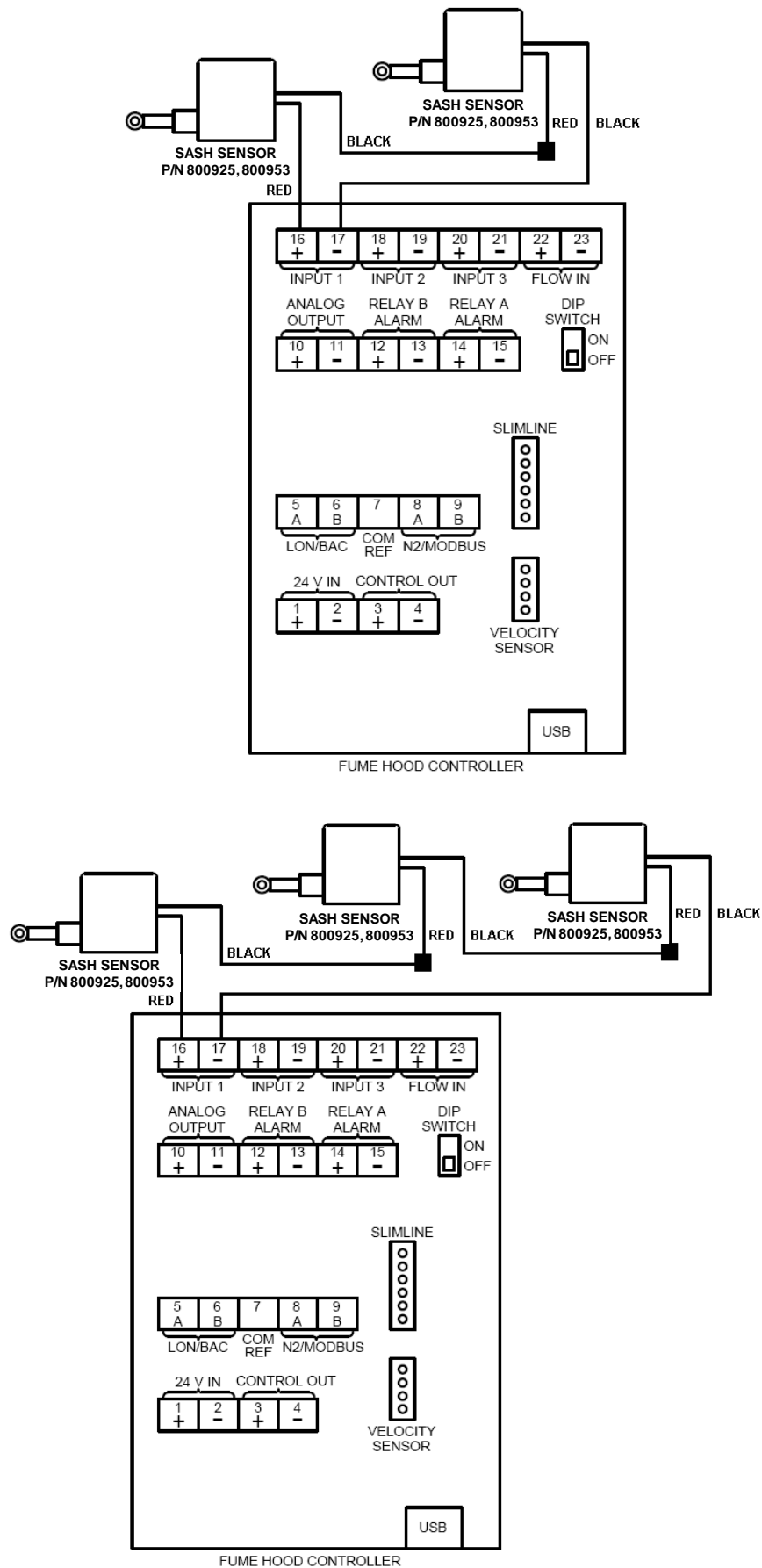

Figure 9: Wiring with Two or Three Vertical Sash Sensors

TSI and the TSI logo are registered trademarks of TSI Incorporated in the United States and may be protected under other country's trademark registrations.



Knowledge Beyond Measure.

TSI Incorporated – Visit our website www.tsi.com for more information.

USA	Tel: +1 800 874 2811	India	Tel: +91 80 67877200
UK	Tel: +44 149 4 459200	China	Tel: +86 10 8219 7688
France	Tel: +33 1 41 19 21 99	Singapore	Tel: +65 6595 6388
Germany	Tel: +49 241 523030		

