

DESIGN AND INSTALLATION CONSIDERATIONS FOR TSI® AEROTRAK® VHP-RESISTANT REMOTE PARTICLE COUNTERS

APPLICATION NOTE CC-111 (A4)

Introduction

A widely used method to inactivate bio-contamination on surfaces in GMP controlled areas is sporicidal gassing using Vaporized Hydrogen Peroxide (VHP). This is the vapor form of Hydrogen Peroxide—H₂O₂. Another term used by industry is Hydrogen Peroxide Vapor (HPV).

VHP is a powerful oxidizing agent and if drawn into a particle counter can damage or contaminate the instrument optics. Damage as a result of exposure can cause false particle counts, calibration errors or a complete particle counter malfunction.

To address the issue, TSI offers a range of VHP resistant remote particle counters with VHP resistant coatings and materials. The model numbers are listed below:

- AeroTrak Model 7510-01FV Remote Particle Counter (0.5 µm, 5 µm @ 1 CFM)
- AeroTrak Model 7510-02FV Remote Particle Counter (0.5 µm, 0.7 µm, 1 µm and 5 µm @ 1 CFM)
- AeroTrak Model 7510-A2FV Remote Particle Counter (0.5 µm, 0.7 µm, 1 µm and 5 µm @ 1 CFM, 4-20 mA)

This application note details key design considerations when implementing VHP resistant continuous particle counters in critical GMP controlled cleanroom environments.

See Application Note CC-108—*TSI AeroTrak Remote Particle Counter Resistance to Vaporized Hydrogen Peroxide (VHP)*, for more detail on the testing to prove the performance of these VHP resistant particle counters, when inadvertently exposed to VHP.

Background

VHP sporicidal-gassing decontamination utilizes a free radical reaction to kill microorganisms on surfaces. Free radicals are molecules or atoms that possess an unpaired electron. Electrons do not like to be unpaired and want to steal an electron from another molecule or atom in order to be paired. This means VHP is highly chemically reactive towards other substances, rendering it an extremely effective biocide.

To produce the vapor, the generation system initially dehumidifies the air and then a 30% -59% Hydrogen Peroxide solution is passed over a vaporizer (a heated plate). The resultant VHP is then circulated or passed through the area at a programmed concentration and time period. This is known as a gassing cycle.



VHP gassing cycles are carefully optimized to achieve a 6-log reduction (1,000,000 to 1) or kill of predetermined numbers of microbes on Biological Indicators (BIs) during validation studies. Gassing cycle times and concentrations will vary according to many factors including overall volume, the surface area, the microbiological flora, and the temperature and relative humidity of the environment being gassed. Typical concentrations range from 140 ppm to 1400 ppm. Seventy-five (75) ppm is considered immediately dangerous to life or health in humans, and 1 ppm for 8 hours a permissible occupational exposure limit (OEL). Cycle times can vary from 10 seconds to minutes to many hours.

There are two main methods used for VHP disinfection which are sometimes referred to as the *wet* and *dry* methods. The *dry* method delivers the vapor to the targeted surface pre-dew point, as gas molecules to the targeted surface. The *wet* method delivers the vapor post dew point as micro condensation to the targeted surface. The micro condensation is invisible to the human eye, and following the aeration phase of the gassing cycle, leaves no residue behind. See Figure 1.

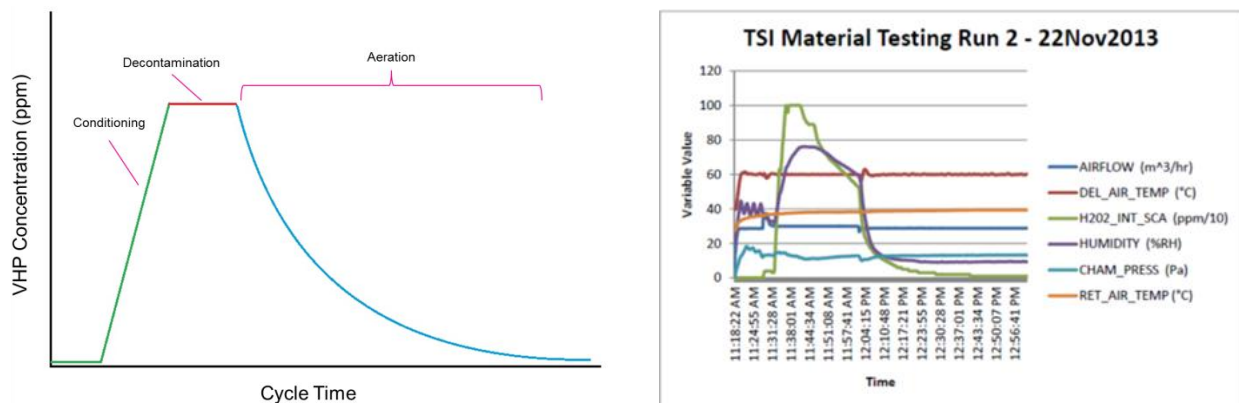

Figure 1. Left graph shows the phases of a VHP gassing cycle. The right hand graph shows an example plot of a real world gassing cycle; the green line denotes VHP concentration over time.

Typical Implementation—Grade A

The purpose of a VHP-resistant sensor is to ensure that the sensor is not damaged when exposed to VHP. Experience has shown that best practice is to not frequently pass VHP through the optics of continuous remote particle counters, even if they are VHP resistant.

There are good reasons for this, including the wide variability in the purity of the Hydrogen Peroxide solution that is vaporized. Another is the changes in pressure, temperature, and humidity inside the particle counter optics assembly, relative to the zone being gassed, which may cause VHP to condense excessively leaving behind residues. The result is that the sensor will need to be eventually removed, cleaned and possibly replaced, negating any advantage gained by having a VHP resistant sensor.

VHP Resistant Remotes—Internal Disinfection?

Prior to the advent of VHP sterilization technology, the particle counter Isokinetic Sample Probe (ISP) and other external surfaces associated with the sample probe were disinfected using cleaning solutions, whilst the vacuum pump was powered down. With this approach, it was impossible to clean the internal optics and associated flow paths of the particle counter without destroying the instrument. Cleaning the internal surfaces of the sample probe and sample tubing required that the remote particle counter be physically removed from the flow path.

The perceived need to disinfect the internal surfaces of a remote particle counter using VHP is generally not risk based. In most cases the contamination risk presented by a remote continuous particle counter to the Grade A—ISO 5 aseptic core is very low, due to its relative distance away from any critical work sites.

In a typical installation, air is sampled via an ISP from the critical work site via sample tubing ~1 meter (3 feet) in length, as shown in Figure 2. Per *US FDA Aseptic Processing Guidance 2004*, the ISP must not normally be more than 1 foot or 30 cm from the work area. The work area is typically raised from the isolator base or floor. As a result, the sample tube length inside the isolator can be ~50 cm (1.5 ft) long. The sample tube continues a further 30-50 cm (1-1.5 ft) directly below the ISP location, beneath the isolator to reach the externally mounted particle counter.

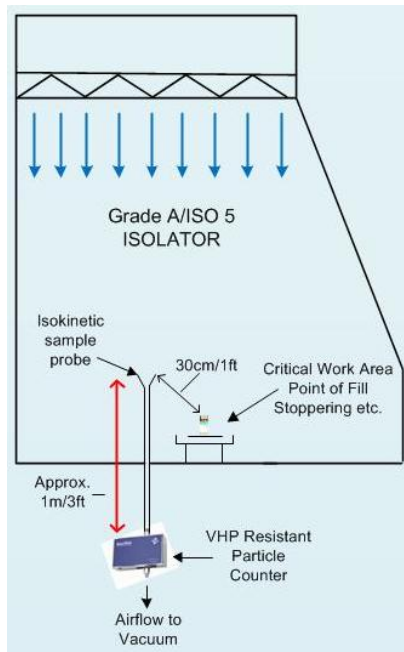

Figure 2. Particle Counter sample tube length is typically 1 m (3 ft) from the critical work site once FDA cGMP 1 ft rule is followed and the particle counter is installed in an accessible external location, underneath the isolator (or RABS)

If the remote particle counter is perceived to be a contamination risk at ~1 meter (3 ft) from the critical work area, then at what point in the flow path does the contamination risk become acceptable? What about other equipment like the non-return valve, vacuum relief valve, vacuum pump and the vacuum pump exhaust filter?

The GMPs do not require particle monitoring to be performed when a disinfection gassing cycle is being executed. This includes no monitoring during critical processing, setup or even at rest, as this is a cleaning activity. Additionally, monitoring air quality whilst live organisms are present during critical processing is not necessary per EU GMP Annex 1 guidance as detailed in Figure 3. It is not necessary to sterilize the internal particle counter flow path surfaces following exposure to this risk, as no such exposure ought to take place.

“For Grade A zones, particle monitoring should be undertaken for the full duration of critical processing, including equipment assembly, except where justified by contaminants in the process that would damage the particle counter or present a hazard, e.g. live organisms and radiological hazards. In such cases monitoring during routine setup operations should be undertaken prior to exposure to risk. Monitoring during simulated operations should also be performed....”

Figure 3
EU GMP Annex 1 Section 9

Importantly, any adverse trend indicating sample tubing or particle counter particulate contamination will be quickly detected by the end user. In Grade A/ISO 5 critical processing environments, the remote particle counter is continuously logging data to a Facility Monitoring System (FMS). The collected data is presented as trends by the FMS software and is regularly reviewed. To this extent, the remote counter is continuously verifying the cleanliness of the sample flow path including the ISP, the sample tubing and the internal particle counter surfaces. Decisions on whether cleaning of these components is required can be made accordingly.

VHP Resistant Remotes—Contamination Risk Scenarios

There is a valid risk scenario in that air may flow backwards towards the critical area should the particle counter vacuum source stop functioning. However a correctly designed system with non-return valves installed in the correct location in the vacuum source tubing as a control measure, will deter this risk scenario (see Figure 4).

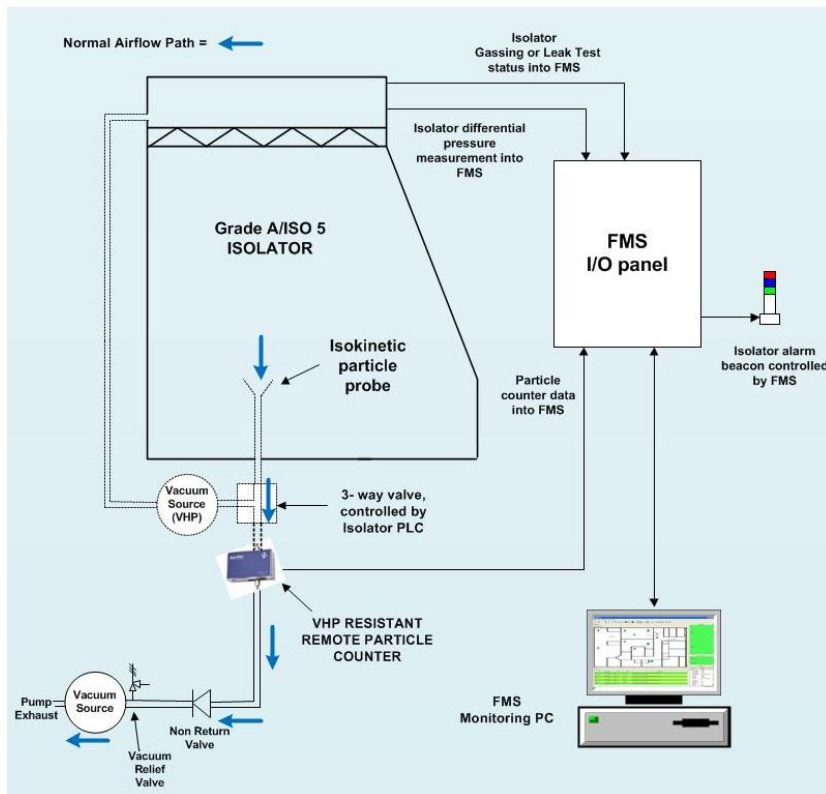

Figure 4. VHP resistant remote particle counter installation scenario in an Isolator (or a Restricted Access Barrier System RABS). The 3-way valve is in the normal sampling configuration. Sample airflow is designated by the blue arrows. FMS I/O panel inputs and alarm beacon connectivity are detailed. Bottom left shows vacuum line non-return valve implementation.

It may well be the case that in Grade A or ISO 5 zones, following a thorough risk analysis, that the particle monitoring probe and some of the sample tubing may be deemed to present a contamination risk to the critical work area. This can be true where long isolator hold times (i.e., times between disinfection) are involved. A control measure to reduce this contamination risk may require VHP disinfection of the sample tubing and isokinetic sample probe. The following section will detail typical practice methodologies for disinfecting the internal surfaces of this sample flow path.

VHP Surface Sterilization and Facility Monitoring Software

A 3-way valve installed in the sample line just before the remote particle counter is used to facilitate VHP sterilization of the inside surfaces of the sample tubing and isokinetic sample probe. During in-operation sampling, the valve allows air to flow through the particle counter as shown in Figure 4. During the gassing cycle, the particle free valve isolates the particle counter, allowing VHP to flow down the sample tube as far as the valve and then be recovered or recirculated back to the isolator plenum, depending on the VHP gassing technique used as shown in Figure 5. The 3-way valve is located close to the remote particle counter inlet beneath the Isolator or RABS. This means that all of the sample flow path, right up to the particle counter inlet is exposed to VHP.

NOTE

The 3-way valve must always be implemented as “fail safe”, should power be lost to the valve, it will be normally closed into the VHP recirculation path shown in Figure 5.

It is typical practice to control the valve using the Isolator PLC or VHP gassing hardware PLC. It is not recommended to utilize the independent monitoring software to perform critical process control activities, such as switching a 3-way valve. The primary purpose of facility monitoring software is to independently *monitor* critical processes, not *control* them.

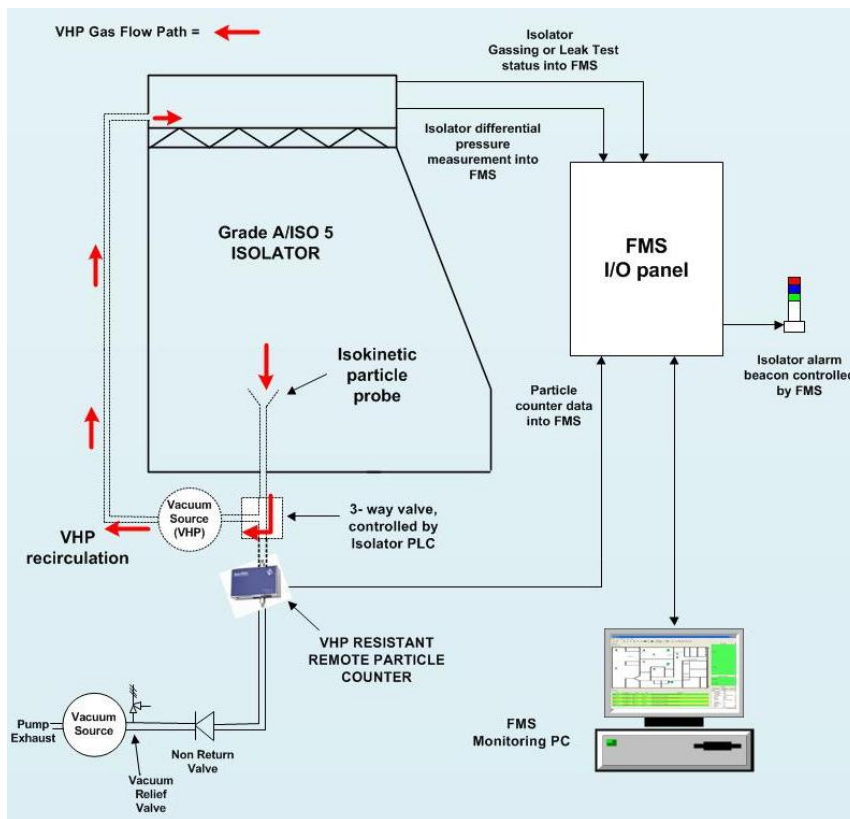

Figure 5. The image shows 3-way valve isolating the particle counter airflow path during a gassing cycle, the flow of VHP gas is designated by the red arrows. This drawing shows VHP recirculating

During a VHP gassing cycle, process changes take place. These can generate nuisance alarms when a remote particle counter is connected to a Facility Monitoring System (FMS). These alarm conditions need to be appropriately handled by the FMS software to avoid wasting valuable time conducting unnecessary root cause investigations. The three main causes of nuisance alarms are:

Flow Failure Hardware Alarm

When the 3-way valve, shown in Figure 5, isolates the remote particle counter inlet during the VHP gassing cycle, the flow rate through the instrument will drop to zero. Under normal operating conditions this causes a flow failure alarm to be indicated by the FMS software and associated alarm beacon. From an end user perspective during cleaning or isolator leak testing, it is advantageous that the FMS software ignores this error message, and not log any particle count data during this time.

One way to solve this problem is to manually stop the monitoring system. However in a modern busy manufacturing environment, other critical activities may continue elsewhere and still require monitoring. The isolator or RABS differential pressure during the gassing cycle may also be of interest. Another approach is to manually disable the effected remote particle counter via the FMS software. However a dependency on any manual FMS software configuration changes during a potentially busy period increases the risk of operator error.

To solve these problems, TSI's FMS software Recipe Switch Driver functionality can dynamically and automatically change the system configuration. Using this integrated functionality, targeted system configuration changes can be made based on the state of a sample point, such as a digital input. In this case, the digital input is simply connected to a volt free contact or relay located in the Isolator (RABS) PLC or VHP gassing hardware. This relay will open or close depending on whether a gassing cycle or an isolator leak test is in progress. See Figure 6 for more details.

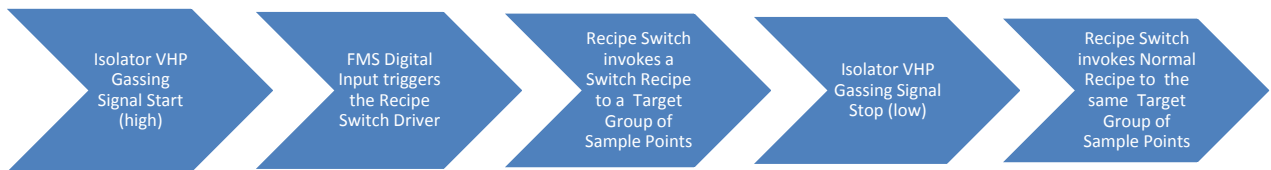

Figure 6.
FMS Recipe Switch Driver functionality process flow

Every sample point in TSI's FMS software has a *Default Recipe* or configuration associated with it. The *Default Recipe* is the normal, operational configuration for any sample point. This includes parameters such as the sample period, alarm and warning limits, and whether the sample point is enabled or not. Importantly, each sample point in FMS can be configured to have multiple recipes associated with it.

An additional recipe is created for the sample point associated with the remote particle counter called *Gassing*. In the *Gassing Recipe*, the particle counter sample point is configured as "disabled". Now there are two recipes for the remote particle counter, *Default* and *Gassing*. The *Gassing (Switch) Recipe* is applied by the Recipe Switch Driver in the FMS software when the isolator is being VHP gassed. The *Default (Normal) Recipe* is applied during normal operation. The recipes will switch based on the isolator (RABS) relay change in state.

The result is that during the VHP gassing cycle, no false alarms due to flow failure are logged or indicated via alarm stacks/beacons, and no particle count data is logged by the FMS. The remote particle counter is disabled by the FMS software automatically during this time.

However there is a potential scenario where false particle counts could be generated when the switch occurs from the *Gassing Recipe* back to the *Default Recipe* at the end of the gassing cycle.

Potential False Particle Counts

When the valve opens to allow air to flow normally through the remote counter at the end of the gassing cycle, an initial pulse of air will flow through the ISP, sample tubing and particle counter. There is a risk that this may dislodge particles previously deposited on internal flow path surfaces. This may result in false particle alarm or warning limit deviations not related to the process at that moment in time.

The Recipe Switch Driver functionality overcomes this problem by applying *Run Up* and *Run Down Recipes* on either side of the *Gassing Recipe*. The *Run Up* and *Run Down Recipes* enable a sample point to gracefully transition between configuration changes. An example is shown in Figure 7.

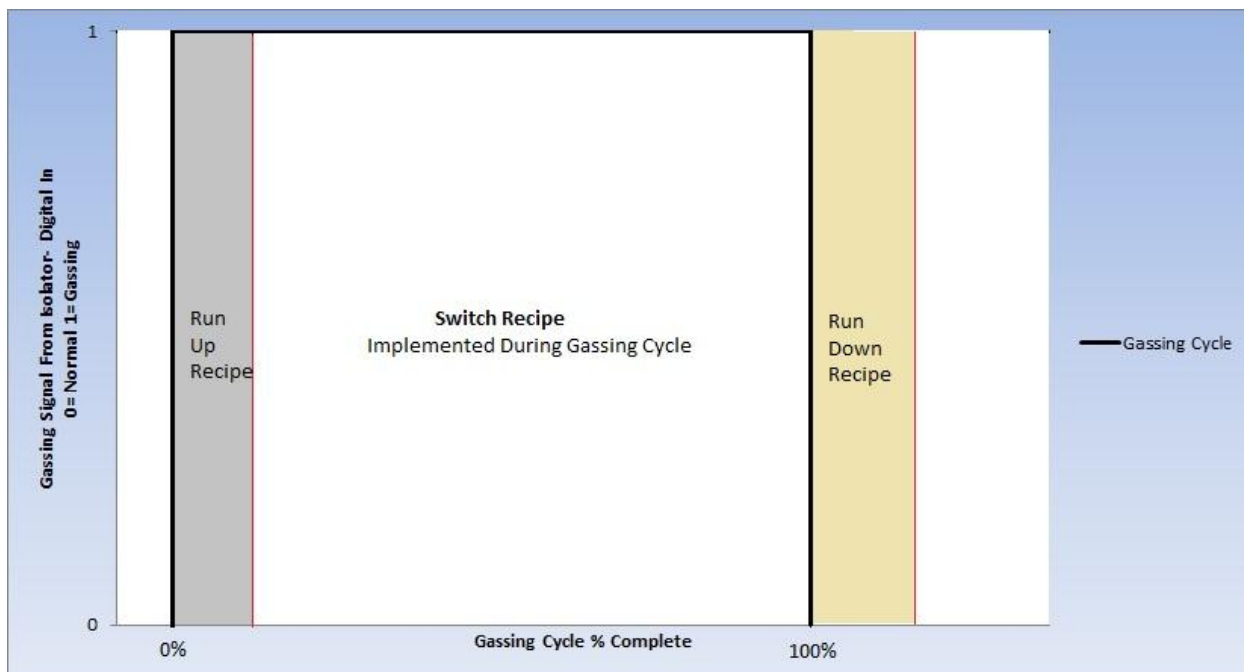

Figure 7.

Details the phases of a gassing cycle as handled by the FMS Recipe Switch driver, the Run Down Recipe phase can be used to collect particle count data from the remote particle counter by temporarily not applying action or alert limits.

For a user configurable period of time, the *Run Down Recipe* will be applied when the Recipe Switch Driver has seen the input sample point, in this case the digital input derived from the isolator gassing relay, return to normal. The *Run Down Recipe* can be configured to log data but not apply alarm and warning limits, or continue to keep the remote particle counter disabled for an additional one or two minutes once the VHP gassing cycle is complete. The purpose is to give time for the particle counter internal flow paths and sample tubes to clean up.

A *Run Up Recipe* is typically not applied to a remote particle counter sample point as it is desirable that the sample point is immediately disabled when the 3-way valve closes. The *Run Up Recipe* is simply not configured. Applications where the *Run Up Recipes* may be used will be detailed in the next section.

Potential Differential Pressure False Alarms

The differential pressure in isolators changes from normal operating conditions during the VHP gassing cycle. End users can use the Recipe Switch Driver in FMS to dynamically change the configuration of a differential pressure sample point. This means the recipe of the differential pressure sample point can be changed based on a gassing signal derived from the isolator. In the isolator, there will be a pressure stabilization period after the VHP gassing cycle has started and the gassing signal has been received. There is a risk that false positive alarms and warning will be generated during this time. To handle this it is possible to apply a *Run Up Recipe* (see Figure 7) which could be configured to disable the differential pressure sensor for 1 or 2 minutes, or just log the data with no warning or alarm limits applied. Similarly, to allow a stabilization period at the end of the gassing cycle, a similar *Run Down Recipe* can be applied.

In summary, *Run Up* and *Run Down Recipes* are optional dynamic configuration changes to the FMS software that prevent occurrences of false positive warnings or alarms during a configuration transition phase.

Typical Implementation in Grade B Zones

In Grade B zones, the particle counter ISP inlet is simply capped off during a VHP gassing cycle.

NOTE

It is typical to install any remote particle counter in a protective enclosure to prevent ingress of cleaning solutions. Similarly, VHP resistant particle counters are usually installed inside stainless steel enclosures to protect them from damage due to cleaning solution ingress.



Figure 8.
Remote particle counter installed in a Stainless Steel enclosure to prevent ingress of cleaning solutions.

Conclusion

In GMP environments, proper risk assessment needs to be conducted. In those applications that use VHP gassing, usually Grade A environments, consideration must be given to particle counting during gassing cycles. Typically, a valve solution is used during the gassing cycle, at which time the FMS software can be configured to disable any potential nuisance alarms, while helping users to collect and report data.

For more information on TSI's VHP products, please contact TSI Technical Support.



UNDERSTANDING, ACCELERATED

TSI Incorporated – Visit our website www.tsi.com for more information.

USA Tel: +1 800 874 2811
UK Tel: +44 149 4 459200
France Tel: +33 4 91 11 87 64
Germany Tel: +49 241 523030

India Tel: +91 80 67877200
China Tel: +86 10 8219 7688
Singapore Tel: +65 6595 6388