

MODEL PN-VAV-45 / PN-VAV-90 VAV BOX UNIVERSAL MOUNTING KIT

INSTALLATION INSTRUCTIONS

These installation instructions cover mounting a TSI pneumatic actuator system to a VAV box or a slip fit rectangular damper. These instructions only cover mounting the actuator.

Note: See TSI SUREFLOW™ Installation Instructions to install the controller.
The mounting kit cannot be used with round dampers.

WARNING: The VAV mounting kit can only be mounted to dampers that rotate either 45 or 90 degrees. A PN-VAV-45 must be installed on a 45 degree VAV box or damper. A PN-VAV-90 must be installed on a 90 degree VAV box or damper.

Component List

Qty	Part Number	Description
1	1206356	Mounting bracket
1	800116	Pneumatic actuator
6	5000261	Sheet metal screws
1	800165	45° Electric to Pneumatic interface (E/P)
<i>or</i>		
1	800119	90° Electric to Pneumatic interface (E/P)

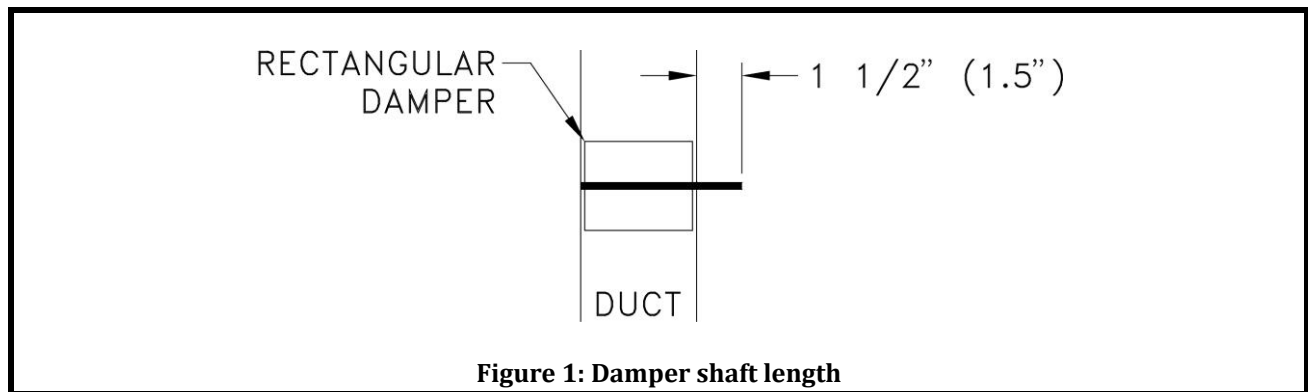

Pneumatic Actuator Installation

The pneumatic cylinder is shipped in a normally open damper configuration. If the installation requires a normally closed damper configuration mount the cylinder on the opposite side of the bracket.

Note: The damper shaft must be a 1/2 inch diameter shaft.

- Remove the E/P (black box) from the actuator assembly, by removing 2 screw assemblies holding E/P case to damper.
- Cut the damper shaft to 1½ inch long (Figure 1).
- Rotate the damper open then closed to ensure full damper rotation.
- Slide the pneumatic actuator arm onto the damper shaft (bottom of Figure 3).
- Center the 1½ inch bracket hole over the damper shaft (Figure 2).
- Screw the bracket to the VAV box or ductwork using sheet metal screws (5 places). Do not install screw under pneumatic cylinder (Figure 2).
- Rotate the damper open then closed to ensure full damper rotation.
- If normally open installation rotate the damper until the damper is completely opened.
- If normally closed installation rotate the damper until the damper is completely closed.
- Align the crank arm with the actuator shaft and tighten the 2 crank arm screws (Figure 3).
- Install the E/P onto the bracket, in reverse of how E/P was removed.
- Install a short pneumatic line between the actuator and **actuator** port on E/P.
- Install 20 PSI clean supply air to the **supply** port on the E/P.

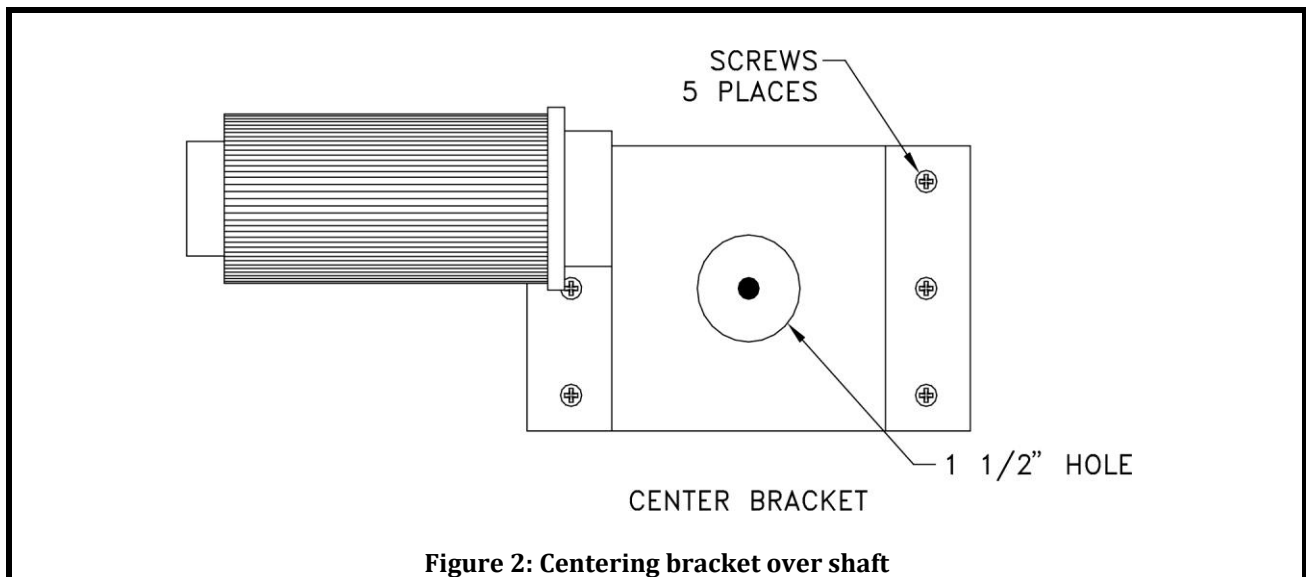

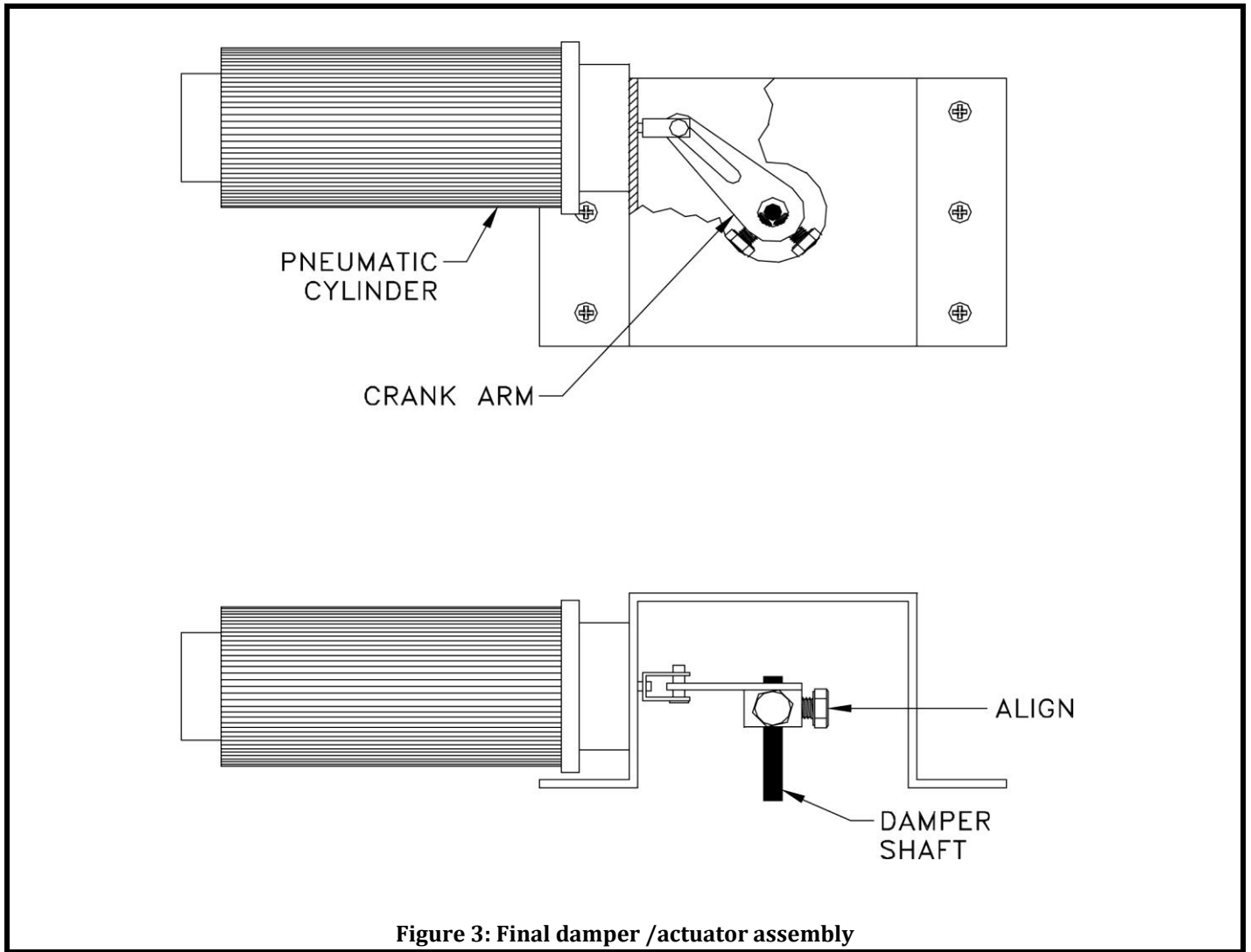

Figure 3: Final damper /actuator assembly

For wiring instructions, refer to the TSI Installation Instructions for the controller model being used.



UNDERSTANDING, ACCELERATED

TSI Incorporated – Visit our website www.tsi.com for more information.

USA Tel: +1 800 874 2811
 UK Tel: +44 149 4 459200
 France Tel: +33 491 11 87 64
 Germany Tel: +49 241 523030

India Tel: +91 80 67877200
 China Tel: +86 10 8251 6588
 Singapore Tel: +65 6595 6388