

# CONSTANT TEMPERATURE THERMAL ANEMOMETER THEORY

APPLICATION NOTE AF-105 (A4)

At the heart of a thermal anemometer are two sensors: an air velocity sensor and a temperature compensation sensor. The velocity sensor is heated to an elevated temperature (relative to the surrounding air) by means of control electronics. The temperature compensation sensor senses the ambient, or surrounding, air temperature and forces the velocity sensor to stay at a constant "overheat" above the ambient.

The sensors form two opposite legs of a Wheatstone bridge (Figure 1). The circuit forces the voltage at points A and B to be equal by means of an operational amplifier. Air flowing past the velocity sensor tends to cool the sensor, thus driving down its resistance. The operational amplifier responds by immediately delivering more power to the top of the bridge to maintain voltage equilibrium at points A and B. As more air flows past the sensor, more power is required to maintain a balanced bridge. Thus, the power going into the top of the bridge is related to the velocity of the air flowing past the sensor. This is the basic principal of operation for constant temperature thermal anemometers.

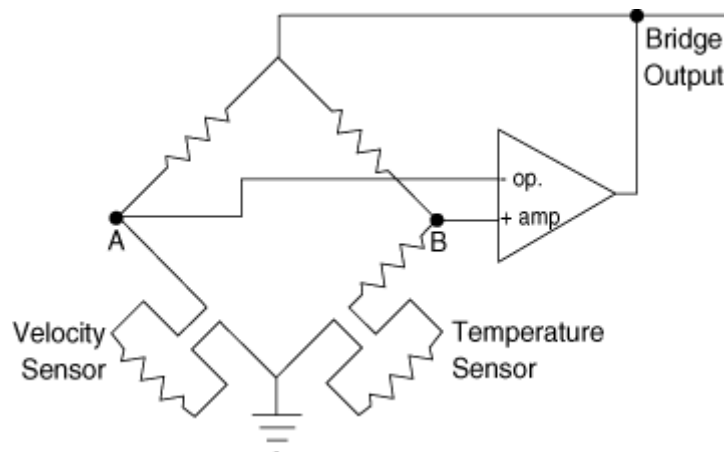

Figure 1: Wheatstone Bridge Diagram



**Airflow Instruments, TSI Instruments Ltd.**

Visit our website at [www.airflowinstruments.co.uk](http://www.airflowinstruments.co.uk) for more information.

**UK**      **Tel:** +44 149 4 459200      **Germany**      **Tel:** +49 241 523030  
**France**      **Tel:** +33 4 91 11 87 64