

CONDENSATION MONODISPERSE AEROSOL GENERATOR MODEL 3475

A CONTROLLED CONDENSATION TECHNIQUE
PRODUCES HIGHLY MONODISPERSE AEROSOL

The Model 3475 Condensation Monodisperse Aerosol Generator (CMAG)* produces highly monodisperse solid or liquid particles in concentrations greater than 10^6 particles per cubic centimeter. It generates spherical and nearly charge-neutral particles from 0.1 to 8 micrometers in diameter.† Particle size and concentration can be varied easily. The CMAG works according to the principle of controlled heterogeneous condensation. This forced condensation enables you to produce a constant output and a high grade of monodispersity, even at very high number concentrations.



Applications:

The Model 3475 is compact, lightweight, and easy to maintain. It is intended for any application requiring the production of high-concentration monodisperse aerosols, including:

- + Human and animal exposure studies
- + Filter testing
- + Particle-sizing instrument evaluation and calibration
- + Smoke-detector performance analyses
- + Wind-tunnel seeding
- + Laser Doppler velocimeter (LDV) seeding
- + General-purpose test-aerosol production

*Availability limited in Europe.
†Depends upon particle material used.

Features and Benefits

A controlled condensation technique produces highly monodisperse aerosol

- + Generates monodisperse particles from 0.1 to 8 μm
- + Produces concentrations $>10^6$ particles/ cm^3



UNDERSTANDING, ACCELERATED

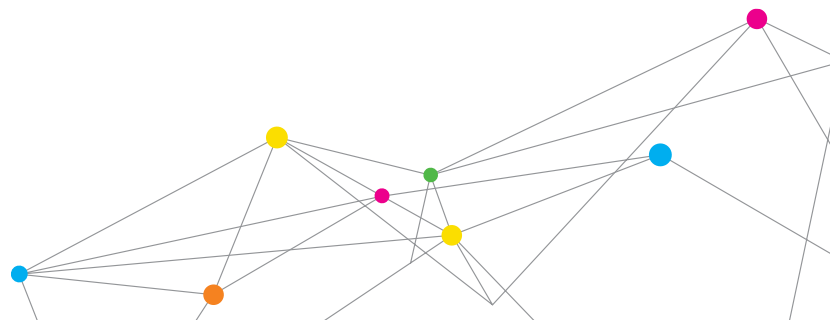

Operation

The Model 3475 CMAG uses a controlled condensation technique to produce monodisperse aerosols. Based on the Sinclair-LaMer principle, this operational approach involves condensing a vapor onto condensation nuclei.

Using nitrogen as the carrier gas, an atomizer inside the CMAG produces a spray from a low-concentration, aqueous solution of sodium chloride. The droplets pass through a drying column, where they dry to form a high-concentration nuclei aerosol. The condensation nuclei travel to a thermostatically controlled saturator vessel and bubble through a substance with low volatility, such as diethylhexyl sebacate (DEHS), dioctyl phthalate (DOP), Emery 3004, or paraffin or carnauba waxes.

The carrier gas, nuclei, and vaporized substance move from the saturator into a reheater unit, which serves to ensure that the aerosol material is completely vaporized. From the reheater unit, the nuclei and vapor move into an air-cooled condensation chimney. It is here that, once a preset supersaturation level has been reached, the controlled heterogeneous condensation process begins, resulting in a highly monodisperse aerosol.

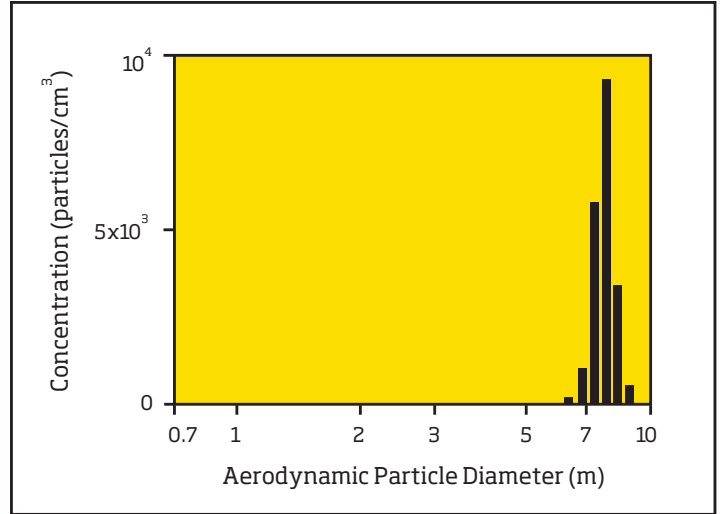

Monodisperse aerosol produced by the Model 3475 using the reduction of the nuclei number concentration

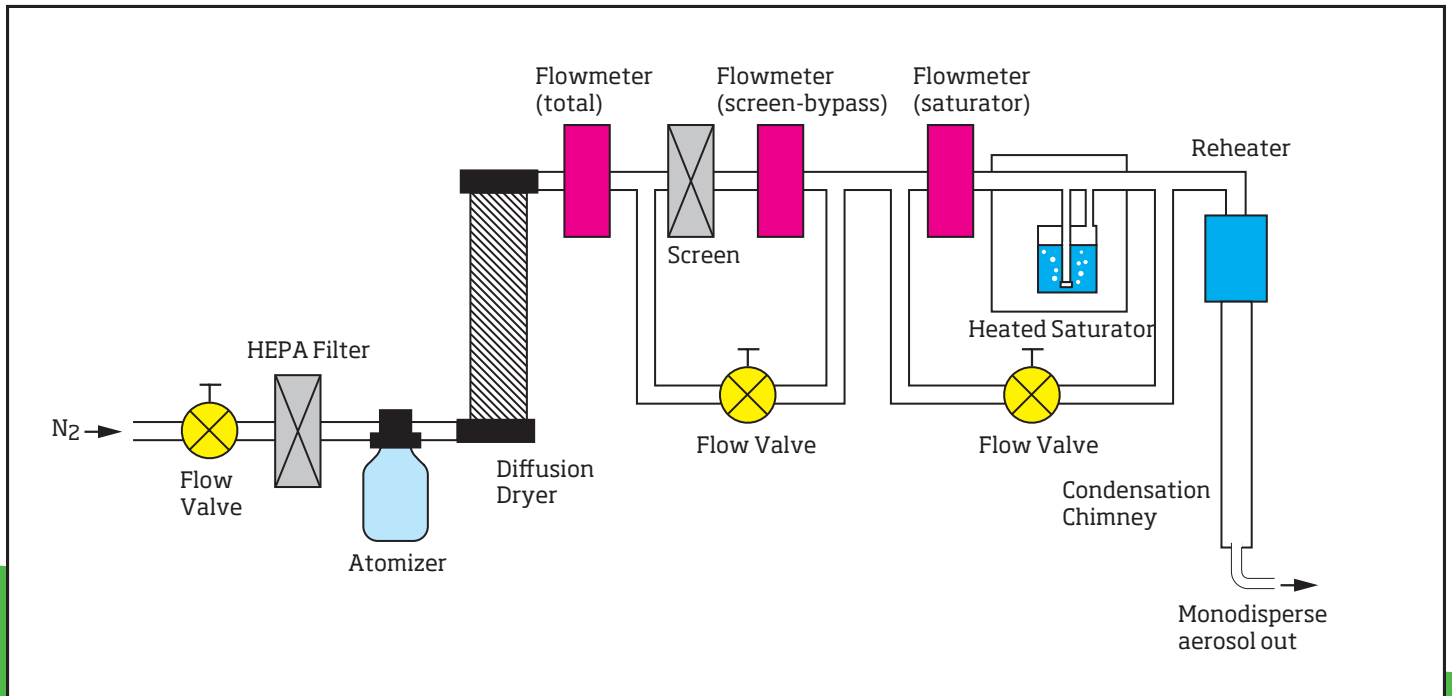

Mean particle size is dependent on the ratio of the vapor concentration to the nuclei number concentration. You can control vapor concentration, and therefore, particle size by adjusting the saturator temperature and the proportion of the total flow passing through the saturator unit.

The CMAG allows you to make very rapid changes to particle size over a limited range by varying the saturator flow rate alone. For instance, with DOP or DEHS, only three different temperature settings are required to cover the range from 0.1 to 5 micrometers. The generator's specially designed aerosol outlet meets the requirement for high monodispersity by selecting the central flow where the temperature gradient is lowest and, consequently, the size distribution is narrowest. To produce monodisperse aerosol with particles up to 8 micrometers, you must divert a portion of the nuclei through a filter, reducing the nuclei number concentration in a controlled manner until you achieve a higher relative concentration of vapor.

Process Aerosol Monitor Accessory

An accessory is available to measure the mean particle size and concentration of monodisperse aerosols produced with TSI's Condensation Monodisperse Aerosol Generator (CMAG). The Model 3375 Process Aerosol Monitor (PAM) connects directly to the CMAG outlet, monitoring output aerosol on a continuous basis. As the highly concentrated aerosol flows through a measuring volume, the PAM uses a photodetector to correlate particle size and concentration with laser intensity. It measures particles in the 0.5 to 10-micrometer range. Concentration is determined independent of the extinction coefficient.

Model 3475 CMAG



Model 3375 PAM



The PAM monitors monodisperse aerosol produced using a Model 3475 CMAG.

SPECIFICATIONS

CONDENSATION AEROSOL GENERATOR MODEL 3475

Mode of Operation

Modified Sinclair-LaMer generator

Particle Type

Liquid DES (nontoxic), DOP, or Emery 3004
Solid Carnauba wax (nontoxic), paraffin,
or stearic acid

Particle-Size Range for Selected Materials

DEHS, DOP 0.1 to 8 μm
Carnauba Wax 0.1 to 4 μm
Stearic Acid 0.1 to 9 μm

Aerosol Geometric Standard Deviation

<1.10 from 0.5 to 8 μm , <1.25 from 0.1 to 0.5 μm

Concentration

>10⁶ particles/cm³

Flow Rate

3.5 to 4.0 L/min

Compressed Gas Requirements

CP Nitrogen at approximately 6 bar or 116 psi

Radioactive or Fluorescent Labeling

Possible

Uniform Unipolar Charging

Possible

Power Requirements

110/220 VAC, 50/60 Hz

Dimensions (LWH)

250 mm × 300 mm × 550 mm (10 in. × 12 in. × 22 in.)

Weight

17 kg (37 lb)

Specifications are subject to change without notice. TSI and the TSI logo are registered trademarks of TSI Incorporated. Emery is a trademark of Henkel Chemical Corp.

Bibliography

Altmann J and C Peters, The Adjustment of the Particle Size at a Sinclair-La Mer-Type Aerosol Generator, *J. Aerosol Science* 23(Supplement 1):S277-S280 (1992)

Peters C and J Altmann, Monodisperse Aerosol Generation with Rapid Adjustable Particle Size for Inhalation Studies, *J. Aerosol Medicine* 6(4):307-315 (1993). (TSI paper A86)

To Order

CONDENSATION AEROSOL GENERATOR

Specify	Description
3475	Condensation Monodisperse Aerosol Generator

Accessories

Specify	Description
3375	Process Aerosol Monitor (see drawing and description on page 2)

Please specify voltage requirements. Models 3475 and 3375 are produced in Germany and marketed by TSI Incorporated. Availability is limited in Europe. Contact your TSI representative for details.



UNDERSTANDING, ACCELERATED

TSI Incorporated - Visit our website www.tsi.com for more information.

USA	Tel: +1 800 874 2811	India	Tel: +91 80 67877200
UK	Tel: +44 149 4 459200	China	Tel: +86 10 8219 7688
France	Tel: +33 1 41 19 21 99	Singapore	Tel: +65 6595 6388
Germany	Tel: +49 241 523030		