

MODEL 8630-CRC-S, 8630-CRC-P PRESSURA™ CLEAN ROOM PRESSURE CONTROLLER

INSTALLATION INSTRUCTIONS

WARNING: The Model 8630-CRC Clean Room Pressure Controller must be wired to 24 VAC only. Wiring the unit to 110 VAC will cause serious damage to the unit and void the warranty.

The pressure sensor must be mounted through the wall between the controlled space (clean room) and referenced space (airlock / hallway).

These installation instructions guide the installer through the installation of the TSI Model 8630-CRC PresSura™ Clean Room Pressure Controller. Please read these instructions thoroughly before beginning installation.

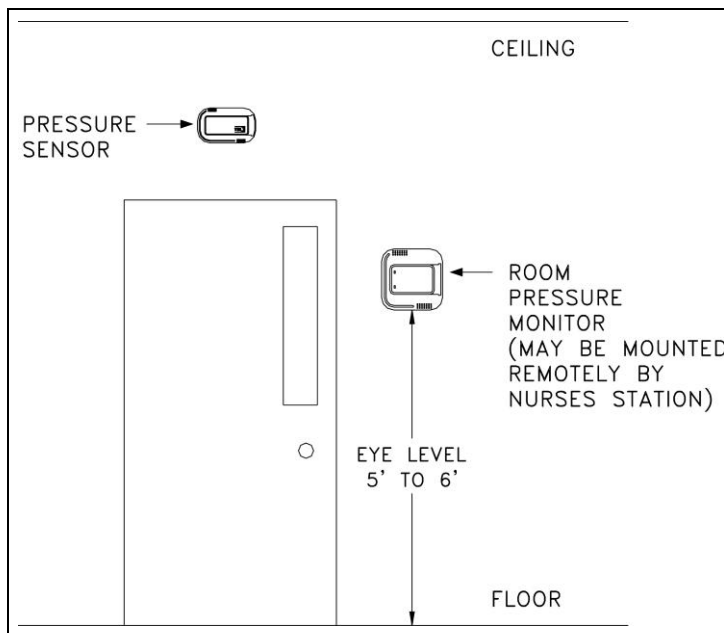

Figure 1: Typical Installation

Component List

Part Number	Qty	Description
801915	1	8630-CRC Clean Room Pressure Controller
800420	1	Transformer
800414	1	Transformer cable
800199	1	Controller Output Cable
<i>and either</i>		
800xxx	1	Pressure Transducer
801913	1	Sensor Port Assembly
800420	1	Transformer
800414	2	Transformer Cable
<i>or</i>		
801912	1	Pressure Sensor Assembly
800248	1	Pressure Sensor Cable

Pressure Sensor Installation

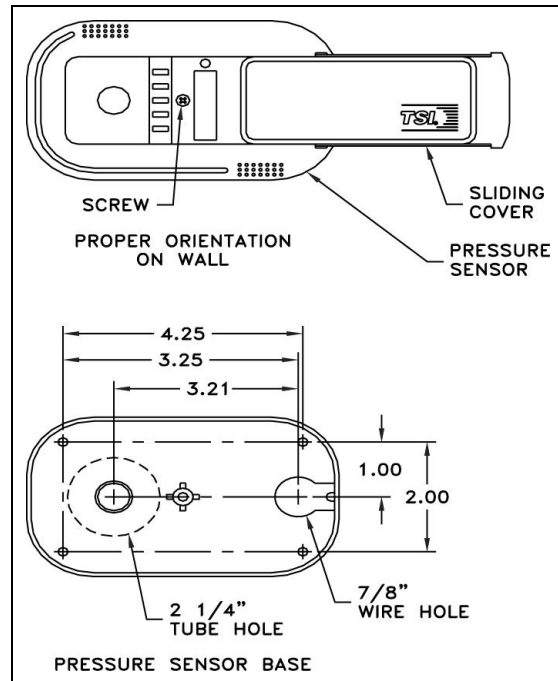

Figure 2: Pressure Sensor Orientation and Mounting Template

WARNING: 801912 pressure sensor must be mounted through the wall between the controlled space (clean room) and referenced space (hallway), exactly as shown in Figure 3 and 4.

1. Determine pressure sensor location (Figures 1, 2, and 3). Pressure sensor typically mounts in the reference space, and the plate mounts in the clean room.

NOTE: Pressure sensor is not symmetrical. If sensor is to be centered over hallway door, measure one inch to the left of center for 2 1/4" hole.

2. The pressure sensor must be orientated on the wall as shown in Figure 2. Looking at the mounted sensor, sensor hole is on the left (2 1/4") and wire hole is on the right.
3. Drill a 2 1/4-inch hole through each side of the wall to accept the sensor tube.
4. Drill a 7/8-inch hole on the side of the wall that the pressure sensor will be mounted. This hole is for the six-conductor sensor cable. Refer to Figure 2 for a hole mounting pattern.
5. Slide sensor cover to right and remove screw that holds the sensor base to the pressure sensor (Figure 2). Remove pressure sensor and store in a safe place.

6. From the side of the wall the sensor will be mounted, slide the sensor tube through the wall. Mark the tube where it is flush with wall. Remove sensor tube and cut tube 1/8 inch shorter than flush marking.

NOTE: If 12" sensor tube is not long enough add a 1" to 2" adapter and extend with 2" OD tube. Do **not** extend sensor tube with 1" tubing.

7. From the side of the wall the sensor will be mounted, slide the sensor tube through the wall. Slide the dummy plate over the end of the tube. Screw the pressure sensor base and dummy plate to the wall (Figure 3).
8. Wire the pressure sensor per Figure 10. Run sensor cable to the Clean Room Pressure Controller 4" x 4" electrical rough-in box.
9. Insert fire protection sealant (provided) into 7/8" wire hole to seal.
10. Install and screw the pressure sensor onto the base. Slide cover to the left to hide the sensor. Finished installation should look as shown in Figure 4.

WARNING: Do **not** touch the sensor element in the pressure sensor. Do **not** run wires through the air passage. Doing so will damage the sensing element.

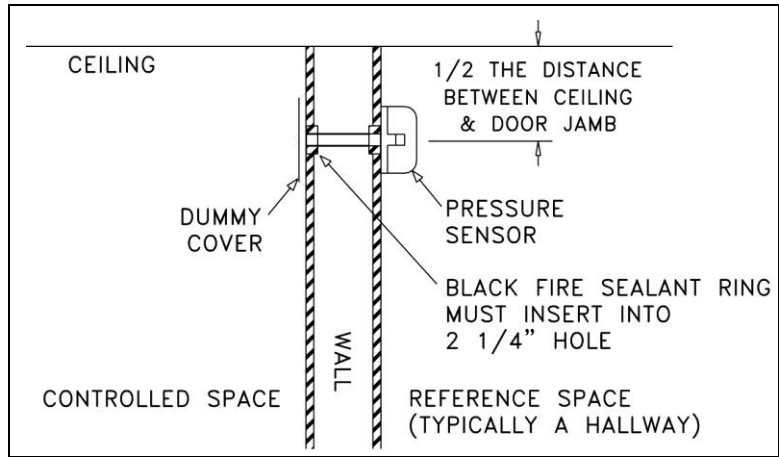

Figure 3: Cutaway View of Mounted Pressure Sensor

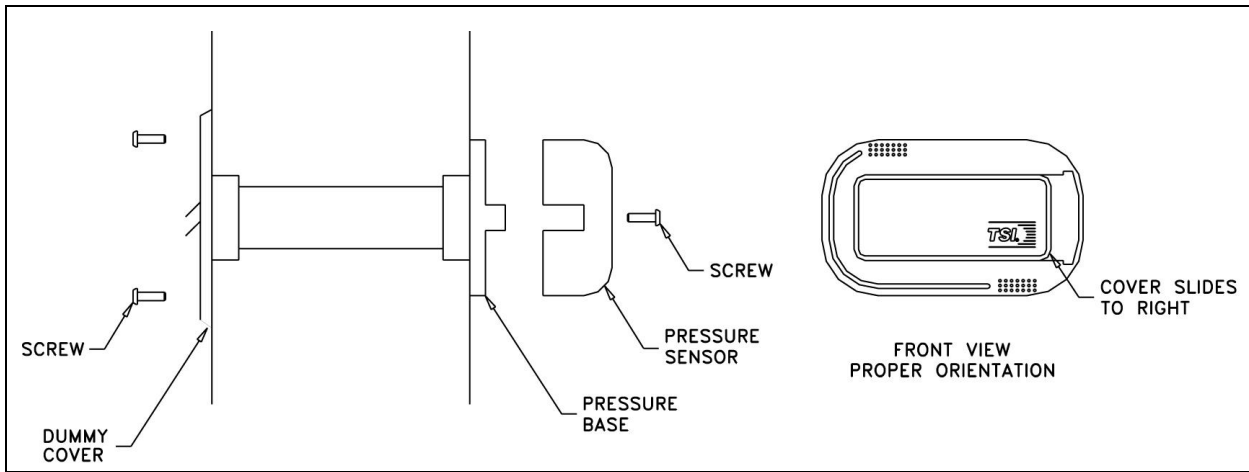

Figure 4: Pressure Sensor Mounting

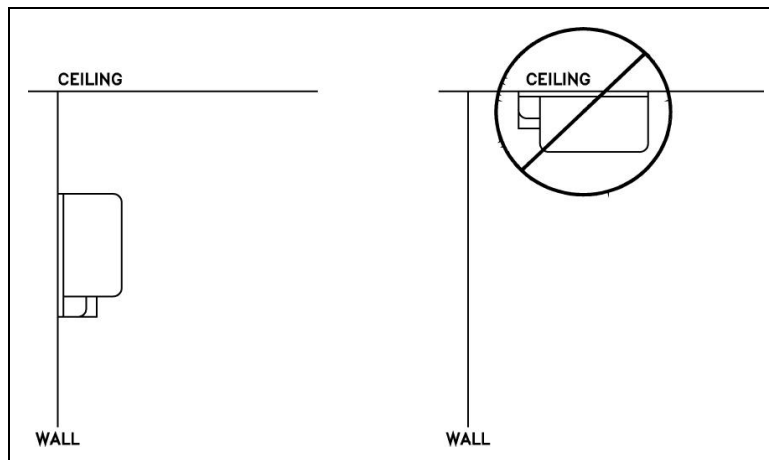

Figure 5: Pressure Transducer Mounting

Pressure Transducer Installation

WARNING: 801913 pressure plates must be mounted in the wall between the controlled space (clean room) and referenced space (hallway), exactly as shown in Figure 6 and 7.

1. Install pressure transducer in desired location (typically above ceiling). The transducer must be mounted on a wall in the correct position per Figure 5 (screws not provided). Do **not** mount pressure transducer to duct or other vibrating surface.
2. Wire the pressure transducer per Figure 11. Run sensor cable to the Clean Room Pressure Controller 4" x 4" electrical rough-in box.
3. Determine pressure sensor location (Figures 1, 6 and 7). Pressure sensor typically mounts in the reference space, and the plate mounts in the clean room.
4. Drill a 2¼-inch hole through each side of the wall to accept the sensor tube.
5. Run pneumatic tubing from transducer to sensor locations. For a positively pressurized space, the high port should be connected to the controlled space and the low port to the reference space. Similarly, for a negatively pressurized space, the low port should be connected to the controlled space and the high to the reference space.
6. Connect the pneumatic tubing to the nipple on the back side of the pressure plate.
7. Insert the pressure plate into the hole in the wall. Screw the pressure plate to the wall. The finished assembly should look like Figure 6.

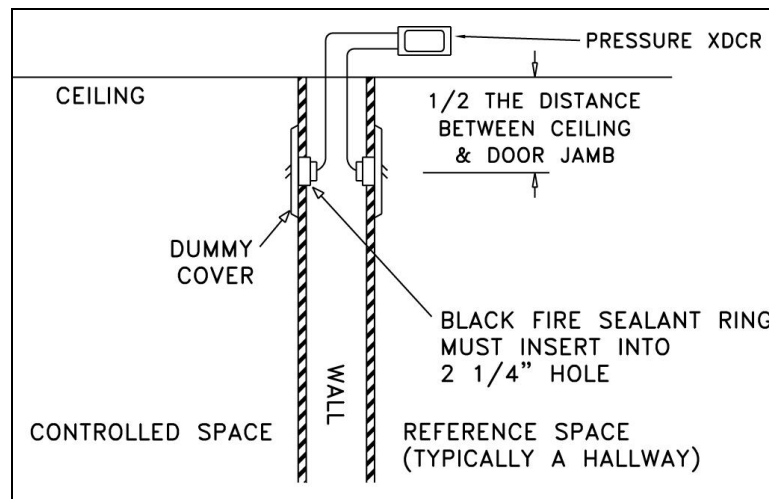

Figure 6: Cutaway View of Mounted Pressure Transducer Assembly

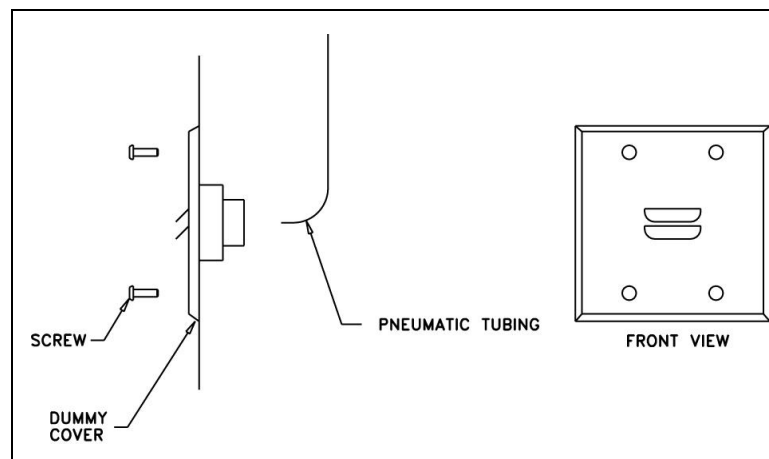

Figure 7: Pressure Transducer Mounting

Transformer Installation

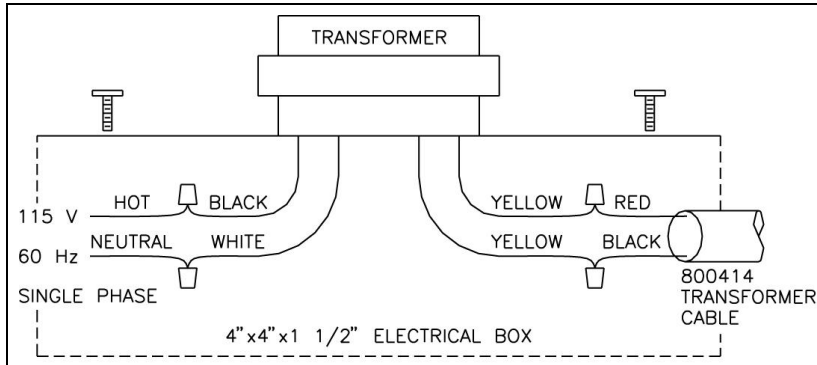

Figure 8: Transformer Installation

WARNING

Make sure no power is applied until all wiring is complete.

Follow all applicable electrical codes, and have qualified personnel install the transformer.

Note: Each system must be installed with supplied transformer. If TSI transformer is discarded and a central transformer is installed, a separate clean transformer must be installed in line between the TSI system and central transformer.

1. Mount a standard 4" x 4" x 1 1/2" electrical box at a convenient location within 20 feet of pressure Controller.
2. Run 115 Volt, single phase, 60-Hertz line voltage (115 VAC) to electrical box. Follow all applicable electrical codes.
3. Connect 115 VAC line voltage HOT wire to BLACK wire on transformer and NEUTRAL wire to WHITE wire on transformer (Figure 8).
4. Connect the RED wire on 800414 transformer cable to either YELLOW wire on the transformer and the BLACK wire to the remaining YELLOW wire.
5. Screw the transformer to the electrical box.
6. Run transformer cable from the transformer electrical box to the pressure Controller. Have at least 8 inches of cable coming out of the pressure Controller rough in electrical box before trimming cable to length.

Pressure Controller Installation

Pressure Controller Rough-in

1. Select the mounting location of the pressure Controller. The construction plans normally show the mounting location. If no location is specified, then the unit is typically installed as shown in Figure 1.
2. Install a standard double gang electrical box (4" x 4").
3. Slide the pressure Controller cover to the right and remove three screws holding the electronics to the base (Figure 9). Remove base.
4. Install the base to the 4" x 4" electrical box. The base's "THIS SIDE UP" arrow must be pointing towards the ceiling.

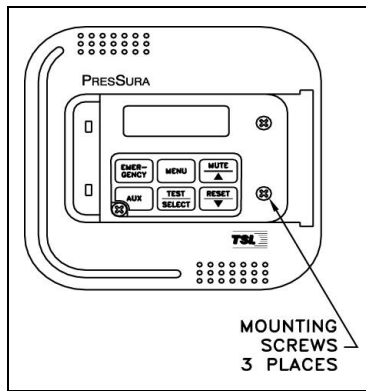

Note Two screws are hidden behind the cover when fully open. The cover will slide to the right approximately 2 inches until a stop is hit. Pull cover to completely remove from electronics and expose the screws.

Figure 9: Pressure Controller Mounting

Pressure Controller Wiring

WARNING: Do **not** connect more than 24 VAC to any terminal.

Do **not** apply voltage to the RS-485 output or analog output. Severe damage may occur to the unit if voltage is applied.

1. Remove the connectors from the back of the Pressure Controller.
2. Refer to the wiring diagram (Figure 10 or 11) for proper wiring installation.
3. If additional options need to be wired, refer to building prints for proper wiring diagram.
4. Plug the connectors back into the Pressure Controller.
5. Carefully push the wires into the electrical box and mount the Pressure Controller. Install three screws to hold Pressure Controller firmly to base. Install cover and slide left to hide display.

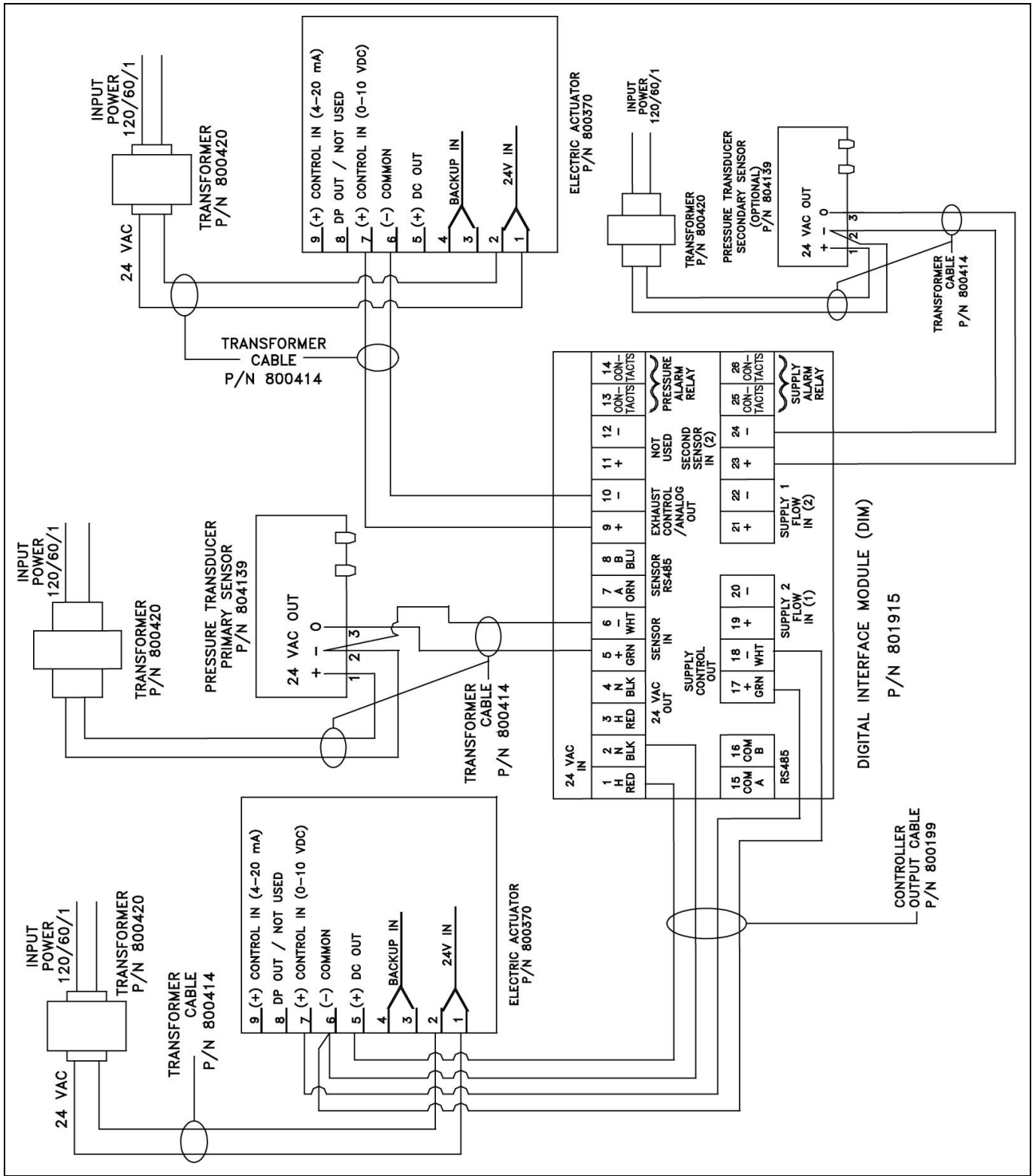

WARNING: Controller must be wired exactly as diagram shows. Making modifications to the wiring may severely damage the unit.

Figure 10: Wiring Diagram with Electric Actuators and Pressure Transducer

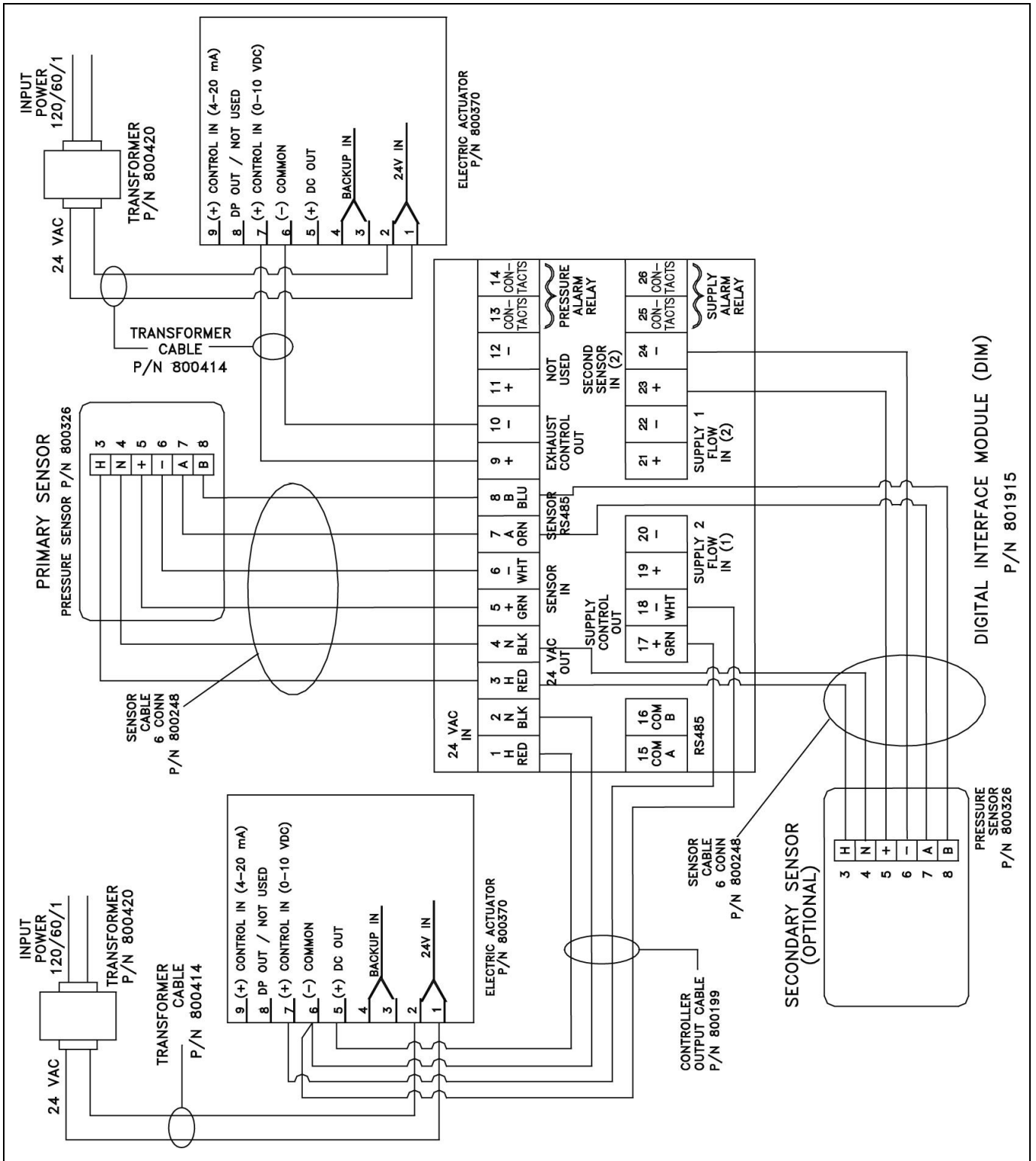

WARNING: Controller must be wired exactly as diagram shows. Making modifications to the wiring may severely damage the unit.

Figure 11: Wiring Diagram with Electric Actuators and Through-The-Wall Sensor

TSI Actuator/Damper Installation

WARNING: Building prints normally determine damper location and mounting configuration. They supersede the guidelines below.

1. The actuators are shipped mounted to the damper. No adjustments are needed prior to mounting the assembly.
2. The damper must be installed with the damper shaft parallel to the ground (Figure 12).
3. Slip-fit dampers mount **INSIDE** the duct work. Flanged dampers bolt to the duct work. No ductwork can be inside of dampers, or interfere with damper rotation.
4. Screw slip-fit damper to duct work using 1-inch or shorter screws. Make sure screws do **not** interfere with damper blade rotation. Bolt flanged dampers securely to ductwork, but do **not** “force” damper to fit (deforms damper).

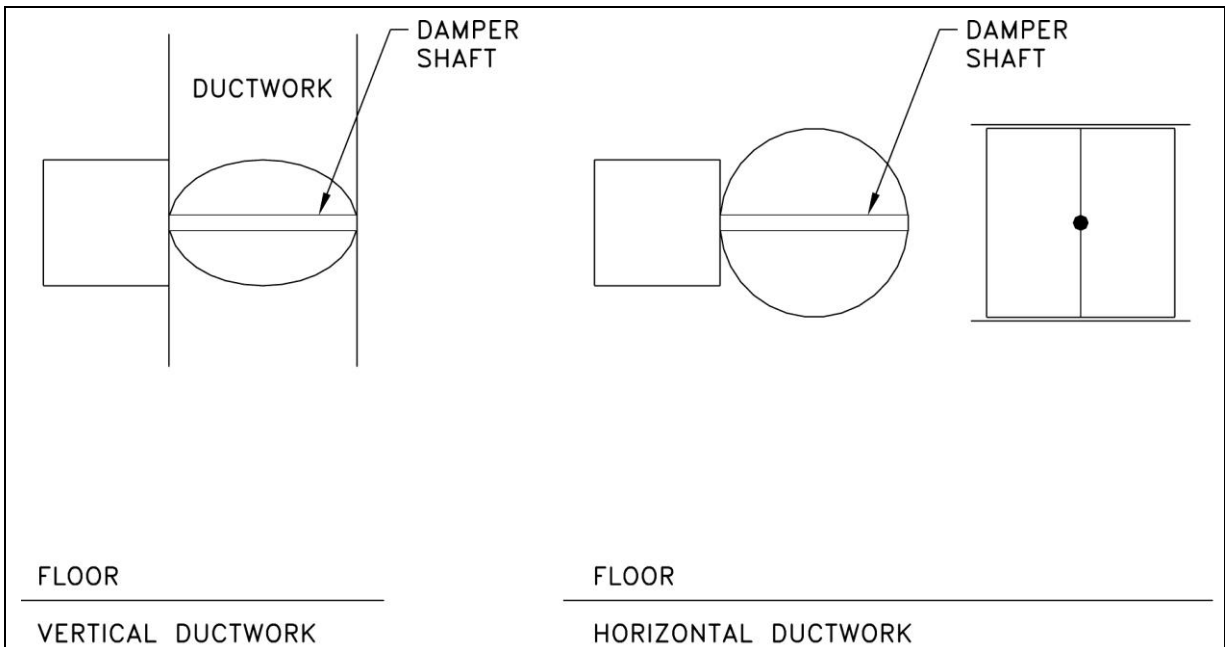

Figure 12: Proper Damper Mounting

If you need assistance installing the system, call TSI Customer Service at 651-490-2811 or 800-874-2811.



UNDERSTANDING, ACCELERATED

TSI Incorporated – Visit our website www.tsi.com for more information.

USA	Tel: +1 800 874 2811	India	Tel: +91 80 67877200
UK	Tel: +44 149 4 459200	China	Tel: +86 10 8251 6588
France	Tel: +33 491 11 87 64	Singapore	Tel: +65 6595 6388
Germany	Tel: +49 241 523030		